

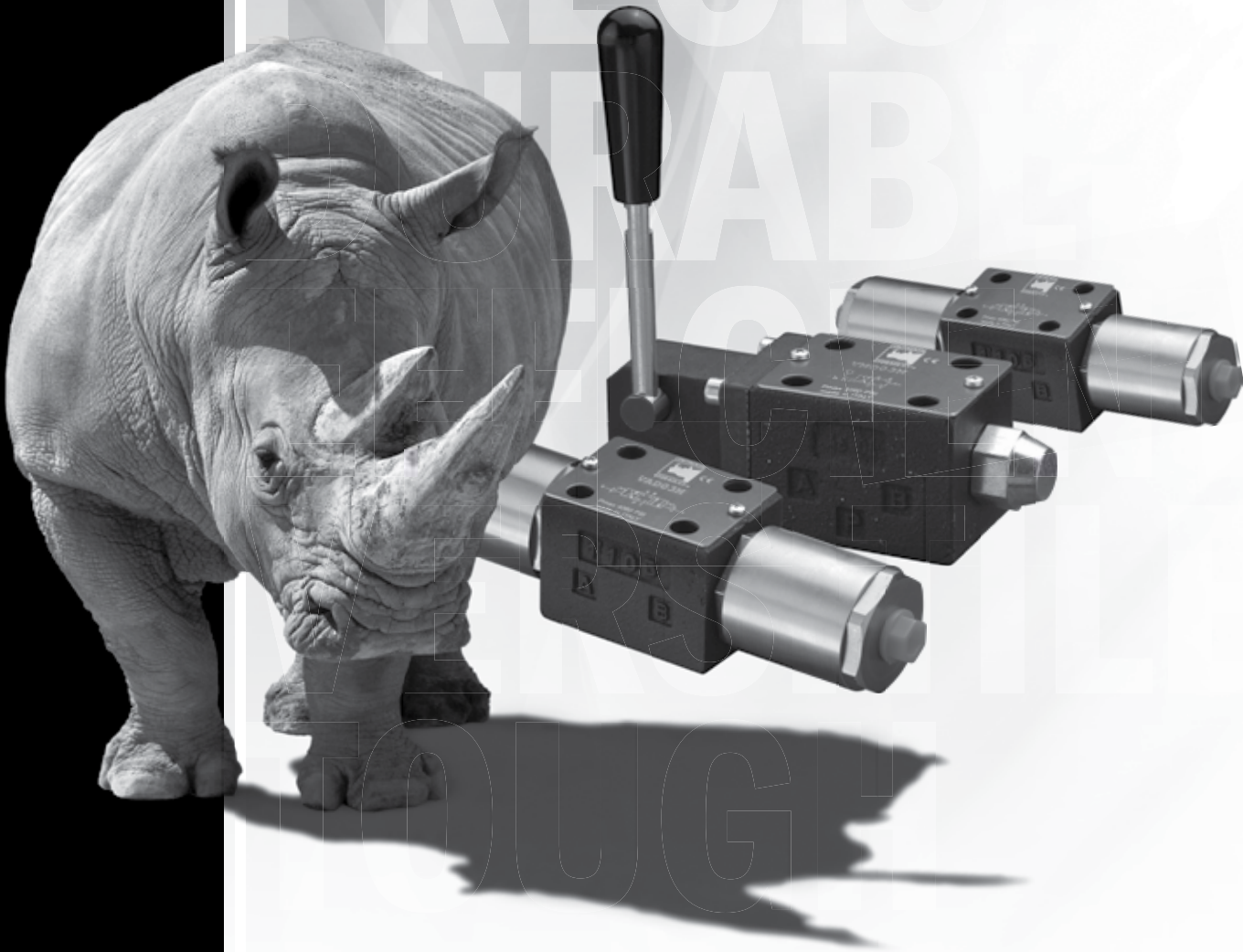

CONTINENTAL HYDRAULICS

VAD03M-VPD03M- VMD03M

AIR, HYDRAULIC, LEVER OPERATED DIRECTIONAL VALVES



VAD03M-VPD03M-VMD03M - AIR, HYDRAULIC, LEVER OPERATED DIRECTIONAL VALVES

VAD03M-VPD03M-VMD03M

AIR, HYDRAULIC, LEVER OPERATED DIRECTIONAL VALVES

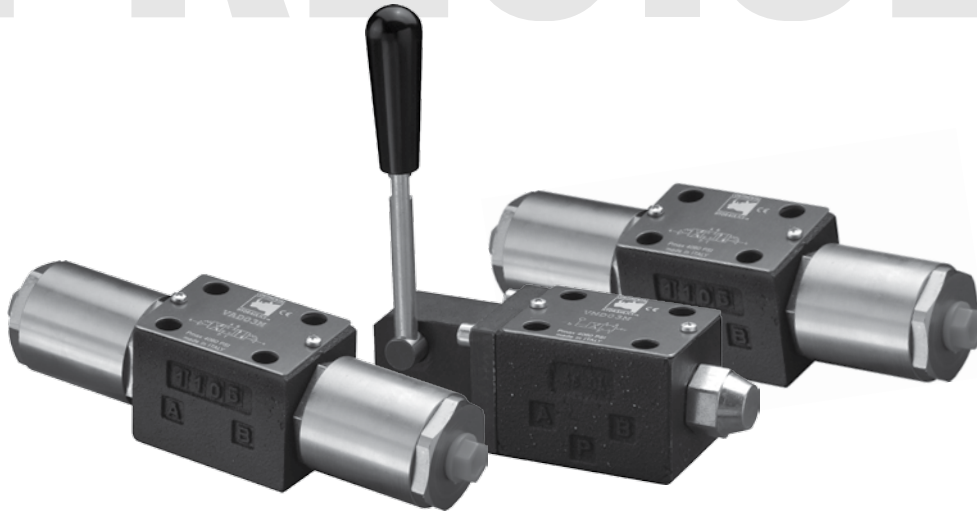

DESCRIPTION

Continental Hydraulics offers directional control valves with air pilot actuation, hydraulic pilot actuation and lever actuation. These valves conform to NFPA D03 and ISO 4401 mounting standards. They are available in both 3 way and 4 way styles.

All versions are available in 2 position spring offset, 2 position detent, 2 position spring centered and 3 position spring centered versions. The lever valve also is available in a 3 position detent model.

A wide range of spools is available.

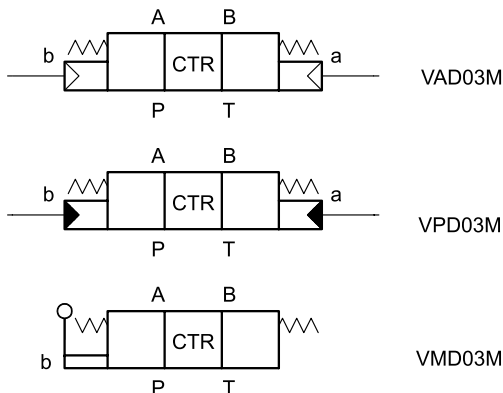

TYPICAL PERFORMANCE SPECIFICATIONS

MAXIMUM OPERATING PRESSURE	P - A - B Ports	5000 psi	350 bar
	T Port VA, VP	360 psi	25 bar
	T Port VM	3000 psi	210 bar
MAXIMUM PILOT PRESSURE	VA	175 psi	12 bar
	VP	3000 psi	210 bar
MINIMUM PILOT PRESSURE	VA	60 psi	4 bar
	VP	215 psi*	15 bar*
FLOW RATE		20 gpm	76 l/min
MOUNTING SURFACE	NFPA D03 ISO 4401-03-02-0-03		
MAXIMUM WEIGHT	VA, VP Single Op.	2.9 lbs	1.3 kg
	VA, VP Dual Op.	3.7 lbs	1.7 kg
	VM - Lever	4.6 lbs	2.1 kg

*NOTE:

The pilot pressure must be at least 215 psi (15 bar) above the T port pressure for the valve to shift properly. The pilot pressure circuit must be designed to allow the pilot pressure to drop rapidly to 0 psi to properly return the spool to its non-actuated position.

RANGE TEMPERATURES	Ambient	-4 to +130 °F	-20 to +54 °C
	Fluid	-4 to +180 °F	-20 to +82 °C
FLUID VISCOSITY	Range	60-1900 SUS	10-400 cSt
	Recommended	120 SUS	25 cSt
FLUID CONTAMINATION	ISO 4406:1999 Class 20/18/15		

IDENTIFICATION CODE

V **D03M** - - - **10** -

DESIGN LETTER

Operator

OPERATOR	
A	Air
P	Oil
M	Lever

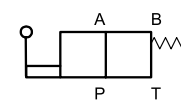
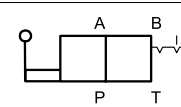
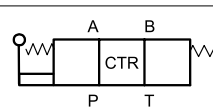
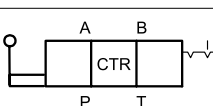
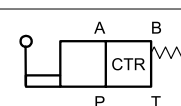
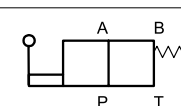
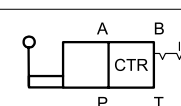
FUNCTION FOR LEVER OPERATOR	
1	 <p>Lever Operator 2 Position Spring Offset</p>
2	 <p>Lever Operator 2 Offset Position Detented (No Spring)</p>
3	 <p>Lever Operator 3 Position Spring Centered</p>
4	 <p>Lever Operator 3 Position Detented (No Spring)</p>
5	 <p>Lever Operator 2 Position Spring Centered</p>
9	 <p>Lever Operator 2 Position - 3 Way Spring Offset</p>
25	 <p>Lever Operator 2 Position Detented (No Spring)</p>

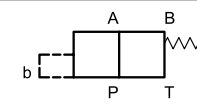
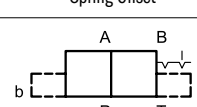
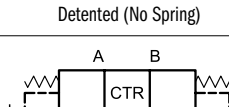
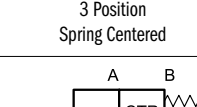
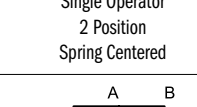
FUNCTION FOR AIR AND OIL OPERATOR	
1	 <p>Single Operator 2 Position Spring Offset</p>
2	 <p>Dual Operator 2 Position Detented (No Spring)</p>
3	 <p>Dual Operator 3 Position Spring Centered</p>
5	 <p>Single Operator 2 Position Spring Centered</p>
9	 <p>Single Operator 2 Position - 3 Way Spring Offset</p>

SEAL	
A	Buna (STD)
G	Viton

MECHANICAL	
OMIT IF NOT REQUIRED	
R	Operator at 'B' port end. Available only with function 1, 5 and 9. Also available on lever valve codes 3 and 4.
90	Lever operator rotated 90° toward tank port.

Spool Type
See Next Page

NOTE: Spool code 9X must have the T port connected to tank.

TYPICAL ORDERING CODE:
VAD03M-3A-A-10-B
VPD03M-3A-A-10-A
VMD03M-3A-A-10-B

SPOOLS						
NAME	SYMBOL	FUNCTION	CENTER POSITION	CROSSOVER	FUNCTION MATCHING	
A			All ports blocked	P→B or P→A T blocked	1, 2, 3, 4*, 5, 25*	
A1			All ports closed	P→B and A→T restricted or P→A and B→T restricted	3, 4*, 5, 25*	
B			All ports open	All ports open	1, 2, 3, 4*, 5, 25*	
E			P and A blocked, and B→T	All ports blocked or P and A blocked and B→T	3, 4*, 5, 25*	
E1			P and A blocked, B restricted to T	All ports blocked or A blocked and B→T restricted		
F			P blocked, A→T and B→T	P blocked and A→T or B→T		
F1			P blocked, A and B restricted to T	P blocked, A or B restricted to T		
G			P to A and B T blocked	P→B or P→A T blocked		
H			P and A to T, B blocked	All ports open, restricted		
J			P→B A and T blocked	P→B and A blocked or all ports blocked		
K			P and B blocked, and A→T	P and B blocked and A→T or all ports blocked		
K1			P and B blocked, A restricted to T	P blocked and A→T restricted or all ports blocked		
L			P→T, A and B blocked	All ports open, restricted		
N			P→A B and T blocked	All ports blocked, or P→A B and T blocked		
Q			P and B to T, A blocked	All ports open, restricted		
X			-	All ports blocked		2*, 9
AN			-	All ports blocked		2 (only VA and VP)
AJ			-	All ports blocked		2 (only VA and VP)

NOTES:

1. Functions marked with * are available with lever operator only.
2. AN and AJ spools are not available with lever operator.
3. These are the standard configurations. Contact Continental Hydraulics for special versions.

PRESSURE DROPS ΔP -Q (OBTAINED WITH VISCOSITY OF 36 CST AT 50 °C)

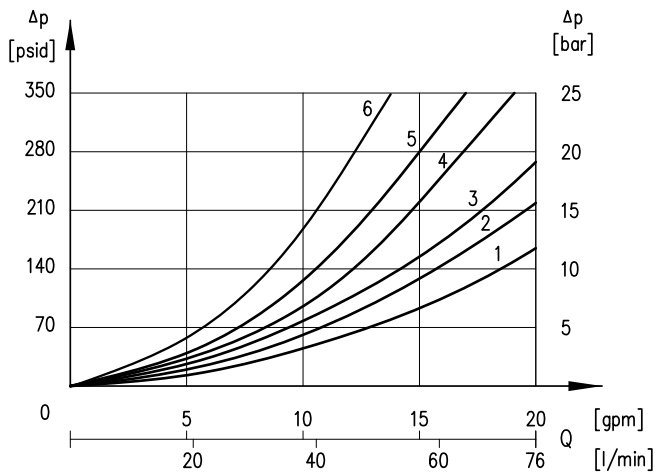

SPOOL	FLOW CURVE NUMBER				
	SHIFTED				CENTER
	P→A	P→B	A→T	B→T	P→T
A, A1, K1, F1, E1	2	2	3	3	
B	1	1	3	3	2
E	2	2	3	1	
F	3	3	1	1	
G	1	3	1	3	
H, Q	4	5	6	6	5
J	2	1	3	3	
K	2	2	1	3	
L	5	5	5	5	4
N	1	2	3	3	
1A, 2A, 2AN, 2AJ	3	3	3	3	
1A, 1B, 2A	2	2	2	2	
9X	3	3			

PERFORMANCE CURVE

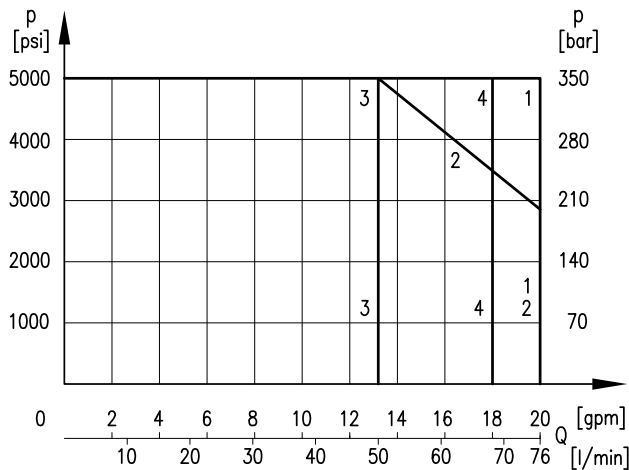

VAD03M, VMD03M

CURVE	SPOOL
1	A, A1, AN, AJ, B, E1, F1, G, K1, J, N, X
2	F
3	E, K, H, L, Q
4	L (only for VMD03M)

VPD03M

CURVE	SPOOLS
2	A, F, 1B
3	B, L, X

NOTES:

1. Valve performance was tested in a four way circuit (full loop). Performances may be reduced from that shown when used in a three-way circuit (half circuit), i.e. A or B port plugged.
2. The values have been obtained according to ISO 6403 norm with filtration according to ISO 4406:1999 class 18/16/13.

OVERALL AND MOUNTING DIMENSIONS FOR PNEUMATIC AND HYDRAULIC OPERATOR

VAD03M-2*, 3*
VPD03M-2*, 3*

Dimensions in mm [IN]

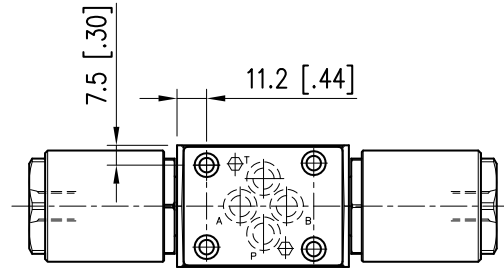

Hexagon:
38 mm [1 1/2"] wrench
Tightening torque:
25-30 lb.ft (35-40 Nm)

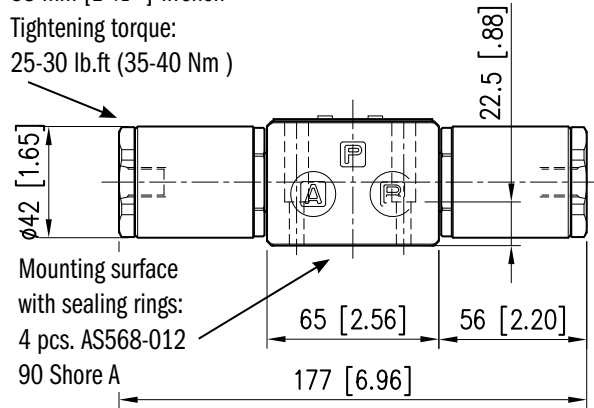
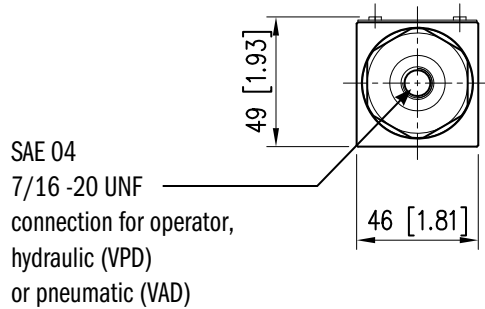

VAD03M-1*, 5*, 9
VPD03M-1*, 5*, 9

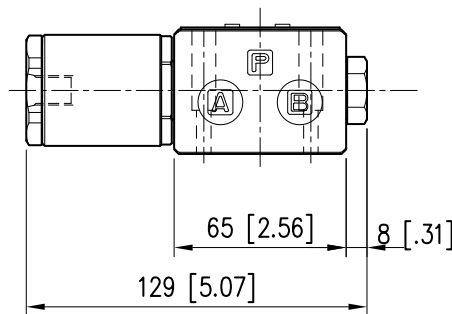

VAD03-1*-R, 5*-R, 9*-R
VPD03-1*-R, 5*-R, 9*-R

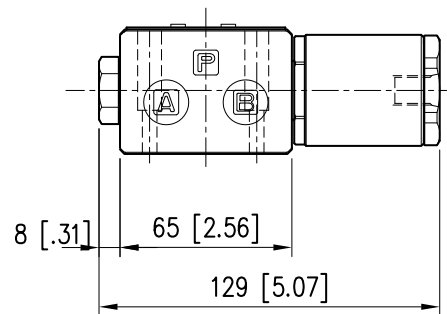

OVERALL AND MOUNTING DIMENSIONS FOR LEVER OPERATED VALVE

VMD03M

Dimensions in mm [IN]

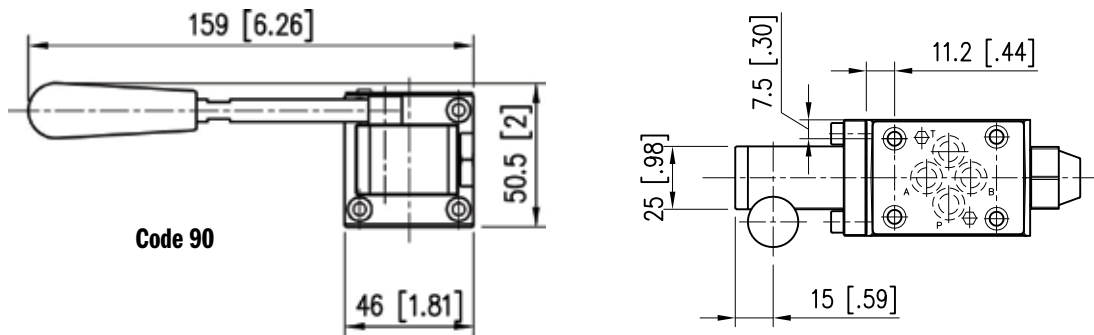

Code 90

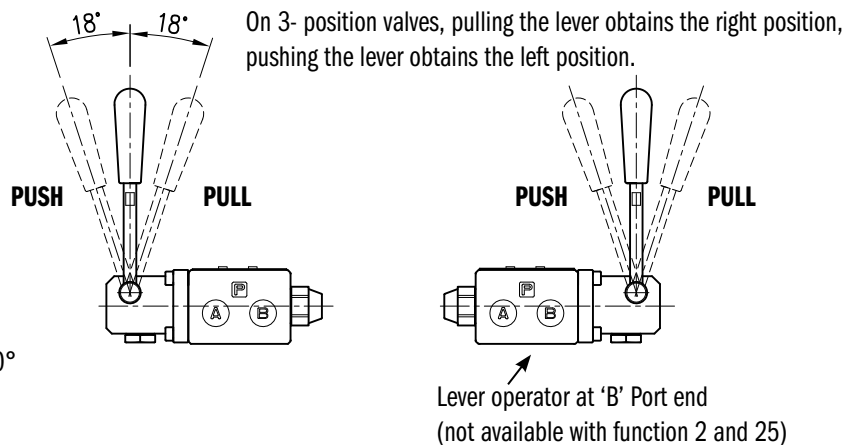
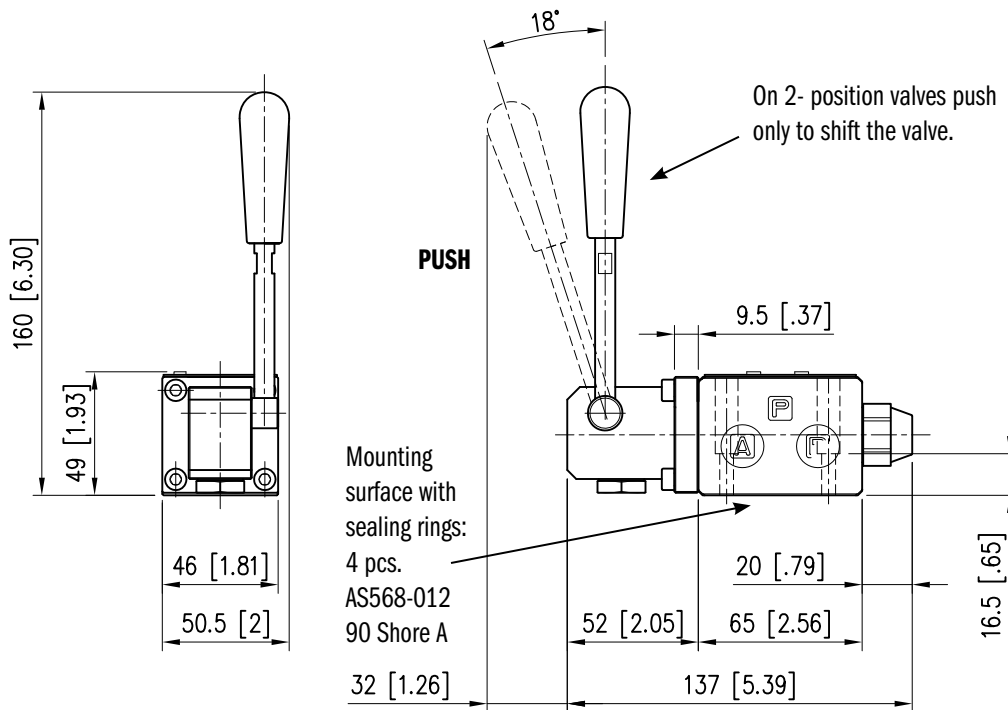

NOTE:

the lever can be oriented by the user directly 180° turned to the standard position by unscrewing the lever and re-mounting it in the desired position.

APPLICATION DATA

FLUIDS

All pressure drops shown on these data pages are based on 170 SUS fluid viscosity and 0.87 specific gravity. For any other specific gravity (G1) the pressure drop (ΔP) will be approx. $\Delta P1 = \Delta P (G1/G)$. See the chart for other viscosities.

FLUID VISCOSITIES	Cst	10	14.5	32	36	43	54	65	76	86	108	216	324	400
	SUS	60	75	150	170	200	250	300	350	400	500	1000	1500	1900
MULTIPLIER		0.77	0.81	0.97	1.00	1.04	1.10	1.15	1.20	1.24	1.31	1.56	1.72	1.83

Use mineral oil-based hydraulic fluids HL or HM type, according to ISO 6743-4. For these fluids, use NBR seals. For fluids HFDR type (phosphate esters) use FPM seals (code G). For the use of other kinds of fluid such as HFA, HFB, HFC, please consult our technical department.

Using fluids at temperatures higher than 180 degrees F causes the accelerated degradation of seals as well as the degradation of the fluids physical and chemical properties.

From a safety standpoint, temperatures above 130 degrees F are not recommended.

RANGE TEMPERATURES:	Ambient	-4 to +130 °F	-20 to +54 °C
	Fluid	-4 to +180 °F	-20 to +82 °C
FLUID VISCOSITY	Range	60 -1900 SUS	10 - 400 cSt
	Recommended	120 SUS	25 cSt
FLUID CONTAMINATION	ISO 4406:1999 Class 20/18/15		

INSTALLATION

The configurations with centering and return springs can be mounted in any position without impairing correct operation.

Valves are fixed by means of screws or tie rods on a flat surface with planarity and roughness equal to or better than those indicated in the relative symbols. If minimum values are not observed, fluid can easily leak between the valve and support surface.

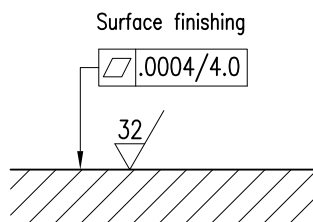

SEAL KIT

Buna Seal Kit for VAD03M	1013311
Viton Seal Kit for VAD03M	1013312
Buna Seal Kit for VPD03M	1013313
Viton Seal Kit for VPD03M	1013314
Buna Seal Kit for VMD03M	1013315
Viton Seal Kit for VMD03M	1013316

BOLT KIT

BD03-100	Valve only	121472
-----------------	------------	--------

SUBPLATES

REAR PORTED	AD03SPB8S	Aluminium	SAE-08	265801AU
	DD03SPB8S	Ductile	SAE-08	265801AH
SIDE PORTED	AD03SPS8S	Aluminium	SAE-08	265801AP
	DD03SPS8S	Ductile	SAE-08	265801AI

NOTES:

1. Max pressure for aluminum subplates: 3000 psi (210 bar)
2. Max pressure for ductile subplates: 5000 psi (350 bar)
3. Always verify subplate port size is proper for the application



ABOUT CONTINENTAL HYDRAULICS

Rugged, durable, high-performance, efficient—the reason Continental Hydraulics' products are used in some of the most challenging applications across the globe. With a commitment to quality customer support and innovative engineering, Continental's pumps, valves, power units, mobile and custom products deliver what the markets demand. Continental has been serving the food production, brick and block, wood products, automotive and machine tool industries since 1962. Learn how our products survive some of the most harsh environments.

SALES@CONTHYD.COM

4895 12th Avenue East, Shakopee, MN 55379 / continentalhydraulics.com / 952-895-6400