

## Deceleration Valves / Deceleration and Check Valves

These valves are available either with or without an integral check valve which allows free reverse flow. Flow rate through the valve is regulated by the movement of the spool, which is operated by a cam. When the spool is depressed, the flow is decreased in Normally Open type valves and increased in Normally Closed type valves. Their principal use is to control the speed of actuators in machine tools and similar applications.

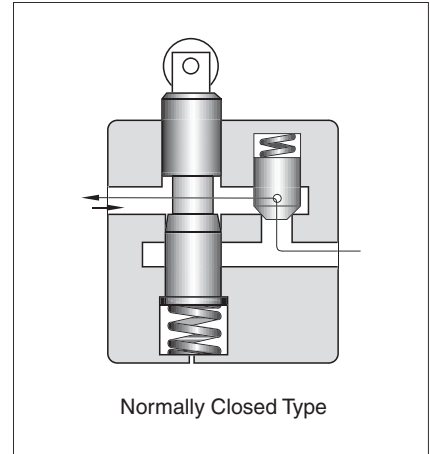
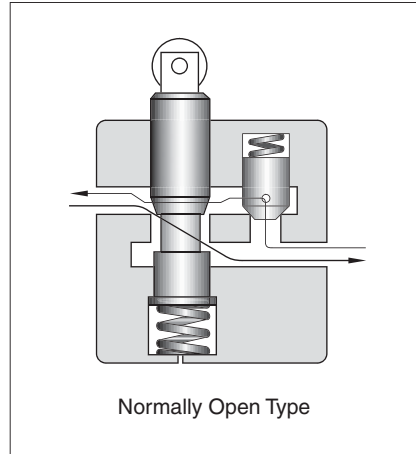

### Specifications

Model Numbers		Max. Flow L/min (U.S.GPM)	Max. Operating Pressure MPa (PSI)	Approx. Mass kg (lbs.)	
Threaded Connection	Sub-plate Mounting			Z*T	Z*G
ZT/ZCT-03-**-22/2280/2290	ZG/ZCG-03-**-22/2290	30 (7.9)	21 (3050)	4.3 (9.5)	4.3 (9.5)
ZT/ZCT-06-**-22/2280/2290	ZG/ZCG-06-**-22/2290	80 (21.1)		8.7 (19.2)	8.7 (19.2)
ZT/ZCT-10-**-22/2280/2290	ZG/ZCG-10-**-22/2290	200 (52.8)		17 (37.5)	17 (37.5)

### Model Number Designation

F-	ZC	T	-03	-T	-C	-22	*		
Special Seals	Series Number	Type of Mounting	Valve Size	With Adjustable Needle Valve for By-Pass Line	Spool Type	Design Number	Design Standards		
<b>F:</b> Special Seals for Phosphate Ester Type Fluids (Omit if not required)	<b>Z:</b> Deceleration Valve	<b>T:</b> Threaded Connection	03	<b>T:</b> With Adjustable Needle Valve (Omit if not required)	<b>None:</b> Normally Open Type	22	<b>None:</b> Japanese Std. "JIS" <b>80:</b> European Design Std. <b>90:</b> N. American Design Std.		
			06			22			
			10			22			
		<b>G:</b> Sub-plate Mounting	03			<b>C:</b> Normally Closed Type	22	<b>None:</b> Japanese Std. "JIS" & European Design Std. <b>90:</b> N. American Design Std.	
			06				22		
			10				22		
	<b>ZC:</b> Deceleration and Check Valve	<b>T:</b> Threaded Connection	<b>T:</b> With Adjustable Needle Valve (Omit if not required)	03	<b>None:</b> Normally Open Type	<b>C:</b> Normally Closed Type	22	<b>None:</b> Japanese Std. "JIS" <b>80:</b> European Design Std. <b>90:</b> N. American Design Std.	
				06			22		
				10			22		
		<b>G:</b> Sub-plate Mounting		03			<b>C:</b> Normally Closed Type	22	<b>None:</b> Japanese Std. "JIS" & European Design Std. <b>90:</b> N. American Design Std.
				06				22	
				10				22	

### Graphic Symbols

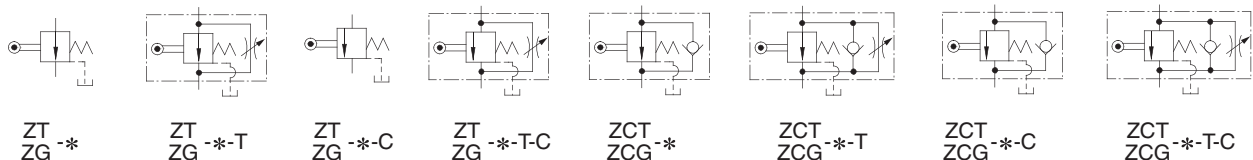

## Instructions

### Force to Depress Spool

Model Numbers	Force N (lbs.)
ZY/ZG ZCT/ZCG-03	150 (337)
ZY/ZG ZCT/ZCG-06	270 (607)
ZY/ZG ZCT/ZCG-10	400 (899)

### Total Leakage at Spool Fully Closed [Viscosity:20 mm<sup>2</sup>/s (98 SSU)]

Model Numbers	Total Leakage cm <sup>3</sup> /min (cu.in./min)				
	Pressure MPa (PSI)				
	1 (145)	2 (290)	5 (730)	10 (1450)	21 (3050)
ZY/ZG ZCT/ZCG-03	9 (.55)	18 (1.10)	44 (2.7)	88 (5.4)	185 (11.3)
ZY/ZG ZCT/ZCG-06	9 (.55)	17 (1.04)	43 (2.6)	86 (5.2)	180 (11.0)
ZY/ZG ZCT/ZCG-10	10 (.61)	20 (1.22)	49 (3.0)	98 (6.0)	205 (12.5)

### Drain Port Back Pressure

Limit the drain port back pressure to 0.1 MPa (15 PSI).

In addition, connect the drain pipe independently and directly to the tank.

## Attachment

### Mounting Bolts

Valve Model Numbers	Socket Head Cap Screw		Qty.
	Japanese Std. "JIS" and European Design Std.	N. American Design Std.	
ZG/ZCG-03	M8 × 75 Lg.	5/16-18 UNC × 3 Lg.	4
ZG/ZCG-06	M10 × 100 Lg.	3/8-16 UNC × 4 Lg.	4
ZG/ZCG-10	M12 × 120 Lg.	1/2-13 UNC × 4-3/4 Lg.	4

## Option

### Bypass throttle valves

To allow a metred flow between ports even when the flow is stopped by the spool.

## Sub-plate

Valve Model Numbers	Japanese Standard "JIS"		European Design Standard		N.American Design Standard		Approx. Mass kg (lbs.)
	Sub-plate Model No.	Thread Size	Sub-plate Model No.	Thread Size	Sub-plate Model No.	Thread Size	
ZG/ZCG-03	ZGM-03-21	Rc 3/8	ZGM-03-2180	3/8 BSP.F	ZGM-03-2190	3/8 NPT	2 (4.4)
ZG/ZCG-06	ZGM-06-21	Rc 3/4	ZGM-06-2180	3/4 BSP.F	ZGM-06-2190	3/4 NPT	3.8 (8.4)
ZG/ZCG-10	ZGM-10-21	Rc 1-1/4	ZGM-10-2180	1-1/4 BSP.F	ZGM-10-2190	1-1/4 NPT	9 (19.8)

- Sub-plates are available. Specify the sub-plate model number from the table above. When sub-plates are not used, the mounting surface should have a good machined finish.



ZT/ZCT-03-\*-22/2280/2290  
 ZT/ZCT-06-\*-22/2280/2290  
 ZT/ZCT-10-\*-22/2280/2290

**DIMENSIONS IN  
 MILLIMETRES (INCHES)**

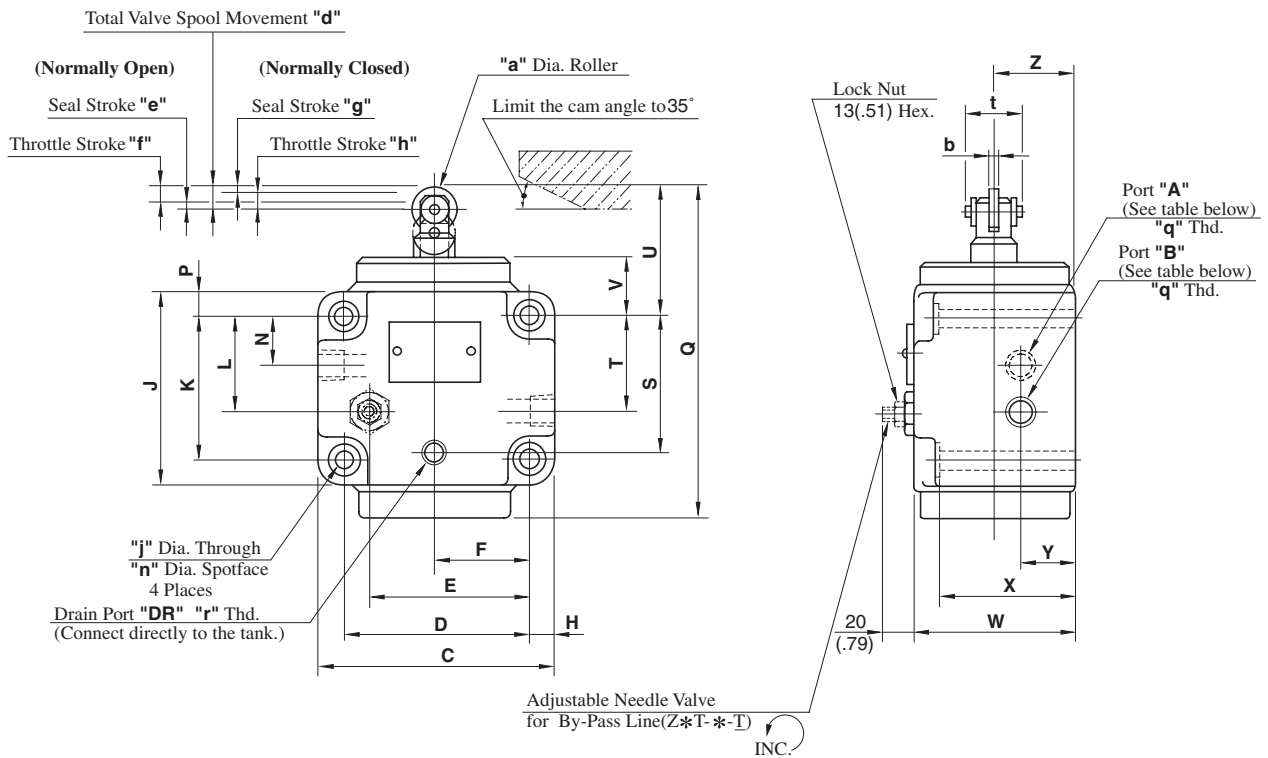

Model Numbers	Port "A"	Port "B"
ZT-*	Controlled flow inlet	Controlled flow outlet
ZCT-*	Controlled flow inlet or Reversed free flow outlet	Controlled flow outlet or Reversed free flow inlet

Model Numbers	"q" Thd.	"r" Thd.
ZT/ZCT-03-*-22	Rc 3/8	Rc 1/4
ZT/ZCT-03-*-2280	3/8 BSP.F	1/4 BSP.F
ZT/ZCT-03-*-2290	3/8 NPT	1/4 NPT
ZT/ZCT-06-*-22	Rc 3/4	Rc 1/4
ZT/ZCT-06-*-2280	3/4 BSP.F	1/4 BSP.F
ZT/ZCT-06-*-2290	3/4 NPT	1/4 NPT
ZT/ZCT-10-*-22	Rc 1-1/4	Rc 1/4
ZT/ZCT-10-*-2280	1-1/4 BSP.F	1/4 BSP.F
ZT/ZCT-10-*-2290	1-1/4 NPT	1/4 NPT

Model Numbers	Dimensions mm (Inches)															
	C	D	E	F	H	J	K	L	N	P	Q	S	T	U	V	W
ZT/ZCT-03	102 (4.02)	80 (3.15)	66 (2.60)	40 (1.57)	11 (.43)	82 (3.23)	60 (2.36)	41 (1.61)	20 (.79)	11 (.43)	141 (5.55)	58 (2.28)	40 (1.57)	56 (2.20)	25 (.98)	70 (2.76)
ZT/ZCT-06	120 (4.72)	98 (3.86)	82 (3.23)	49 (1.93)	11 (.43)	106 (4.17)	84 (3.31)	57 (2.24)	32 (1.26)	11 (.43)	176 (6.93)	81 (3.19)	57 (2.24)	65 (2.56)	27 (1.06)	95 (3.74)
ZT/ZCT-10	160 (6.30)	132 (5.20)	103 (4.06)	66 (2.60)	14 (.55)	140 (5.51)	112 (4.41)	75 (2.95)	40 (1.57)	14 (.55)	224 (8.82)	106 (4.17)	75 (2.95)	80 (3.15)	32 (1.26)	110 (4.33)

Model Numbers	Dimensions mm (Inches)												
	X	Y	Z	a	b	d	e	f	g	h	j	n	t
ZT/ZCT-03	60 (2.36)	25 (.98)	35 (1.38)	18 (.71)	6 (.24)	10 (.39)	2 (.08)	8 (.31)	2 (.08)	8 (.31)	8.8 (.35)	14 (.55)	24.5 (.96)
ZT/ZCT-06	85 (3.35)	32 (1.26)	50 (1.97)	22 (.87)	8 (.31)	13 (.51)	3 (.12)	10 (.39)	3 (.12)	10 (.39)	11 (.43)	17.5 (.69)	29 (1.14)
ZT/ZCT-10	96 (3.78)	40 (1.57)	55 (2.17)	28 (1.10)	10 (.39)	18 (.71)	3 (.12)	15 (.59)	3 (.12)	15 (.59)	13.5 (.53)	21 (.83)	34 (1.34)

ZG/ZCG-03-\*-22/2290  
 ZG/ZCG-06-\*-22/2290  
 ZG/ZCG-10-\*-22/2290

DIMENSIONS IN  
 MILLIMETRES (INCHES)

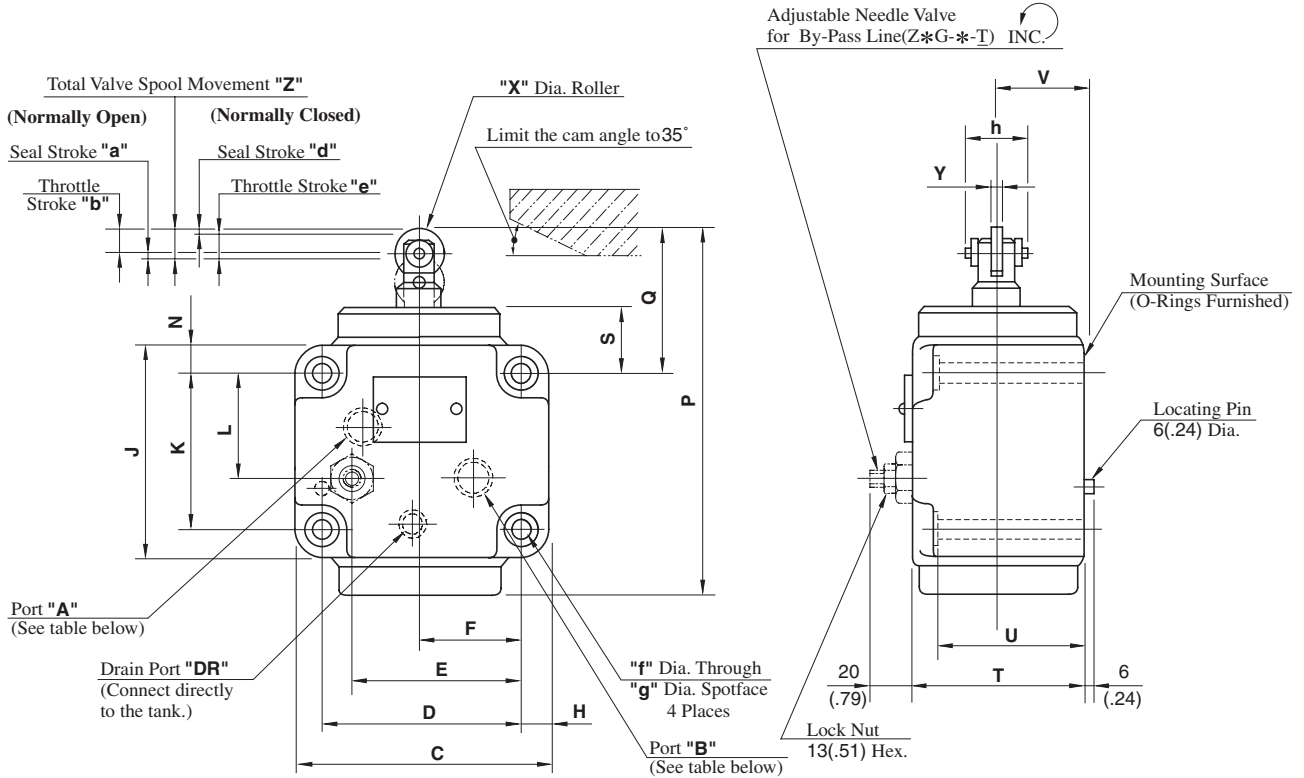

Model Numbers	Port "A"	Port "B"
ZG-*	Controlled flow inlet	Controlled flow outlet
ZCG-*	Controlled flow inlet or Reversed free flow outlet	Controlled flow outlet or Reversed free flow inlet

Model Numbers	Dimensions mm (Inches)												
	C	D	E	F	H	J	K	L	N	P	Q	S	T
ZG/ZCG-03	102 (4.02)	80 (3.15)	66 (2.60)	40 (1.57)	11 (.43)	82 (3.23)	60 (2.36)	41 (1.61)	11 (.43)	141 (5.55)	56 (2.20)	25 (.98)	70 (2.76)
ZG/ZCG-06	120 (4.72)	98 (3.86)	82 (3.23)	49 (1.93)	11 (.43)	106 (4.17)	84 (3.31)	57 (2.24)	11 (.43)	176 (6.93)	65 (2.56)	27 (1.06)	95 (3.74)
ZG/ZCG-10	160 (6.30)	132 (5.20)	103 (4.06)	66 (2.60)	14 (.55)	140 (5.51)	112 (4.41)	75 (2.95)	14 (.55)	224 (8.82)	80 (3.15)	32 (1.26)	110 (4.33)

Model Numbers	Dimensions mm (Inches)											
	U	V	X	Y	Z	a	b	d	e	f	g	h
ZG/ZCG-03	60 (2.36)	35 (1.38)	18 (.71)	6 (.24)	10 (.39)	2 (.08)	8 (.31)	2 (.08)	8 (.31)	8.8 (.35)	14 (.55)	24.5 (.96)
ZG/ZCG-06	85 (3.35)	50 (1.97)	22 (.87)	8 (.31)	13 (.51)	3 (.12)	10 (.39)	3 (.12)	10 (.39)	11 (.43)	17.5 (.69)	29 (1.14)
ZG/ZCG-10	96 (3.78)	55 (2.17)	28 (1.10)	10 (.39)	18 (.71)	3 (.12)	15 (.59)	3 (.12)	15 (.59)	13.5 (.53)	21 (.83)	34 (1.34)

**D**  
 Deceleration Valves  
 Deceleration and Check Valves

ZGM-03-21/2180/2190  
 ZGM-06-21/2180/2190  
 ZGM-10-21/2180/2190

**DIMENSIONS IN  
 MILLIMETRES (INCHES)**

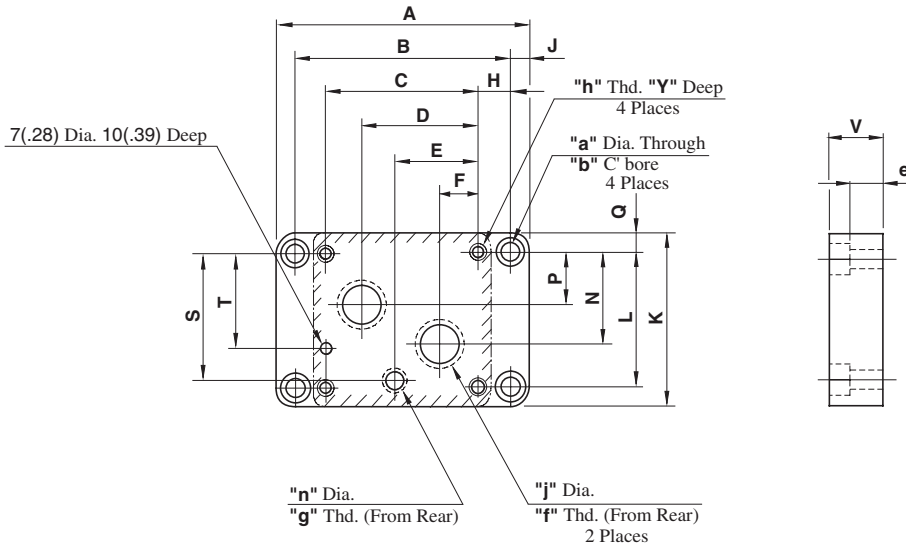

Model Numbers	Thd. Size			mm (Inches)	
	"f" Thd.	"g" Thd.	"h" Thd.	j	n
ZGM-03-21	Rc 3/8	Rc 1/4	M8	14 (.55)	6.2 (.24)
ZGM-03-2180	3/8 BSPF	1/4 BSPF		15 (.59)	
ZGM-03-2190	3/8 NPT	1/4 NPT		14 (.55)	
ZGM-06-21	Rc 3/4	Rc 1/4	M10	23 (.91)	11 (.43)
ZGM-06-2180	3/4 BSPF	1/4 BSPF		24.5 (.96)	
ZGM-06-2190	3/4 NPT	1/4 NPT		23 (.91)	
ZGM-10-21	Rc 1-1/4	Rc 1/4	M12	29 (1.14)	11 (.43)
ZGM-10-2180	1-1/4 BSPF	1/4 BSPF			11.7 (.46)
ZGM-10-2190	1-1/4 NPT	1/4 NPT			11 (.43)

Model Numbers	Dimensions mm (Inches)													
	A	B	C	D	E	F	H	J	K	L	N	P	Q	S
ZGM-03	146 (5.75)	124 (4.88)	80 (3.15)	60 (2.36)	42 (1.65)	20 (.79)	22 (.87)	11 (.43)	85 (3.35)	60 (2.36)	40 (1.57)	20 (.79)	12.5 (.49)	58 (2.28)
ZGM-06	160 (6.30)	138 (5.43)	98 (3.86)	74 (2.91)	53 (2.09)	24 (.94)	20 (.79)	11 (.43)	108 (4.25)	84 (3.31)	57 (2.24)	32 (1.26)	12 (.47)	81 (3.19)
ZGM-10	218 (8.58)	190 (7.48)	132 (5.20)	98 (3.86)	70 (2.76)	34 (1.34)	29 (1.14)	14 (.55)	140 (5.51)	112 (4.41)	75 (2.95)	40 (1.57)	14 (.55)	106 (4.17)

Model Numbers	Dimensions mm (Inches)					
	T	V	Y	a	b	e
ZGM-03	44 (1.73)	26 (1.02)	18 (.71)	11 (.43)	17.5 (.69)	15.2 (.60)
ZGM-06	60 (2.36)	35 (1.38)	18 (.71)	11 (.43)	17.5 (.69)	24.2 (.95)
ZGM-10	87 (3.43)	45 (1.77)	25 (.98)	14 (.55)	21 (.83)	31.5 (1.24)

Hydraulic Fluid: Viscosity 20 mm<sup>2</sup>/s (98 SSU), Specific Gravity 0.850

## ■ Pressure Drop for Reversed Free Flow

**ZCT-03**  
**ZCG-03**

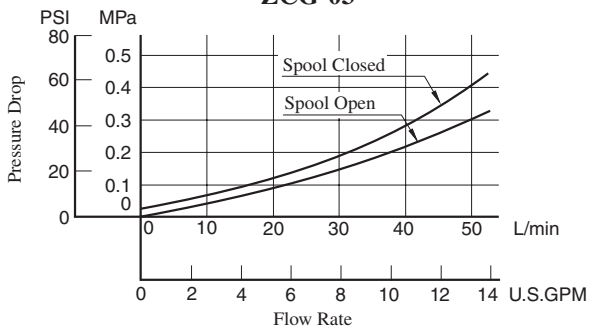

**ZCT-06**  
**ZCG-06**

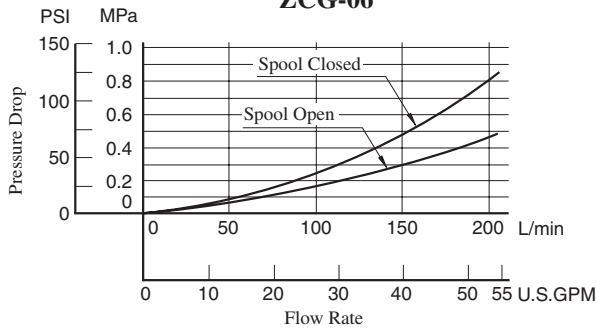

**ZCT-10**  
**ZCG-10**

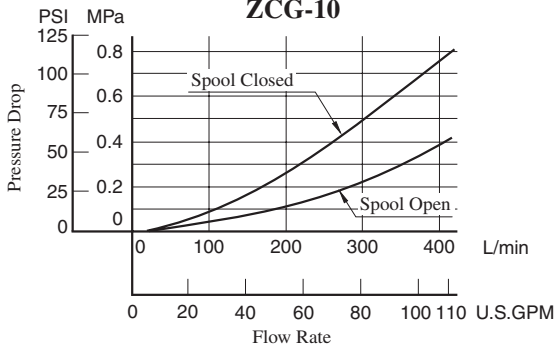

## ■ Metred Flow vs. Spool Depression

**Z\*T-03**  
**Z\*G-03**

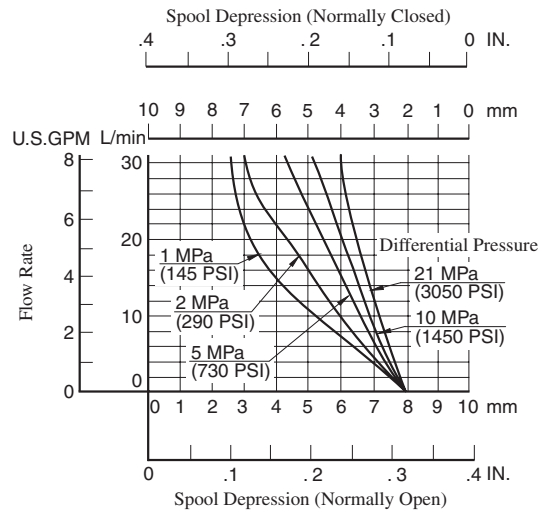

**Z\*T-06**  
**Z\*G-06**

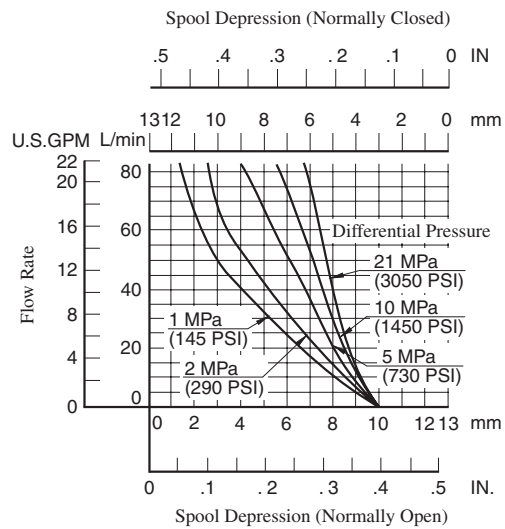

**Z\*T-10**  
**Z\*G-10**

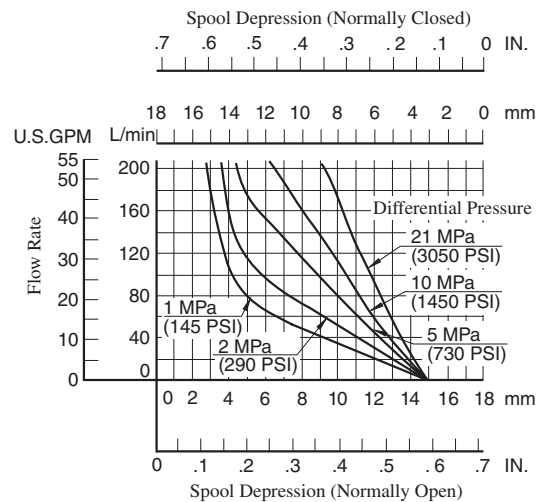

Hydraulic Fluid: Viscosity 20 mm<sup>2</sup>/s (98 SSU) , Specific Gravity 0.850

■ Metred Flow for Needle Valve

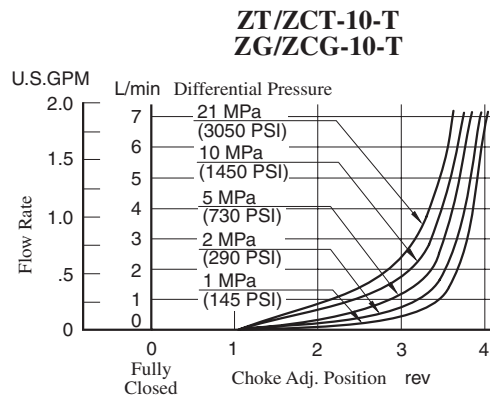
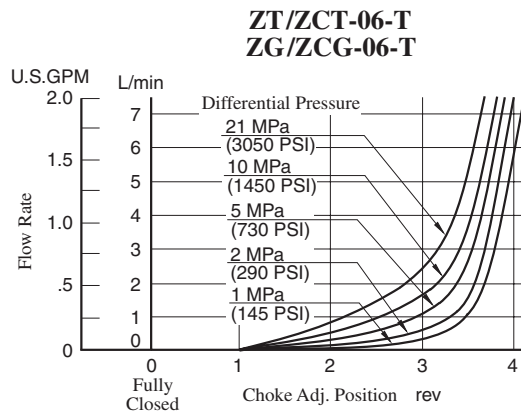
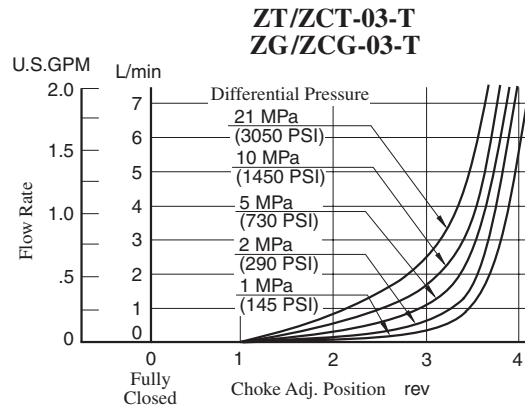

## List of Seals

ZT/ZCT-03-\*-22/2280/2290  
 ZT/ZCT-06-\*-22/2280/2290  
 ZT/ZCT-10-\*-22/2280/2290

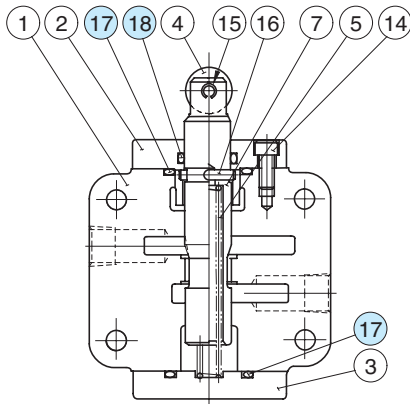

With Check Valve  
(ZCT-\*)

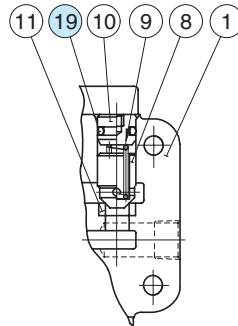

With Adjustable Needle Valve  
for By-Pass Line

(ZT  
ZCT-\*T)

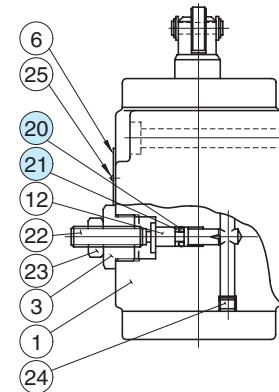

### List of Seals

Item	Name of Parts	Part Numbers			Qty.
		ZT ZCT-03	ZT ZCT-06	ZT ZCT-10	
17	O-Ring	SO-NB-P32	SO-NB-P36	SO-NB-P49	2
18	O-Ring	SO-NA-P20	SO-NA-P25	SO-NA-P32	1
19	O-Ring	SO-NB-P12	SO-NB-P18	SO-NB-P22A	1
20	O-Ring	SO-NA-P5	SO-NA-P5	SO-NA-P5	1
21	Back Up Ring	SO-BB-P5	SO-BB-P5	SO-BB-P5	1

Note: When ordering the seals, please specify the seal kit number from the table right.

### List of Seal Kits

Valve Model Numbers	Seal Kit Numbers
ZT-03	KS-ZT-03-22
ZT-06	KS-ZT-06-22
ZT-10	KS-ZT-10-22
ZCT-03	KS-ZCT-03-22
ZCT-06	KS-ZCT-06-22
ZCT-10	KS-ZCT-10-22

ZG/ZCG-03-\*-22/2290  
 ZG/ZCG-06-\*-22/2290  
 ZG/ZCG-10-\*-22/2290

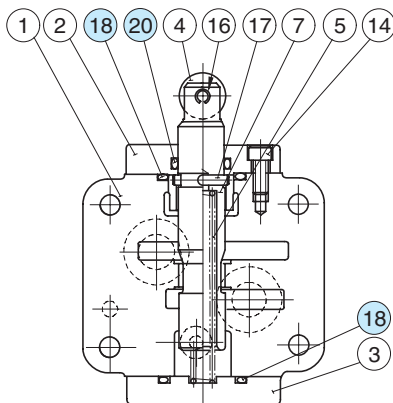

With Check Valve  
(ZCG-\*)

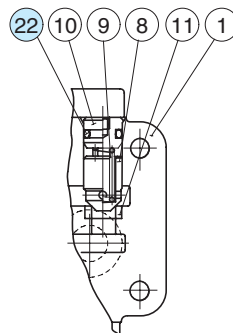

With Adjustable Needle Valve  
for By-Pass Line

(ZG  
ZCG-\*T)

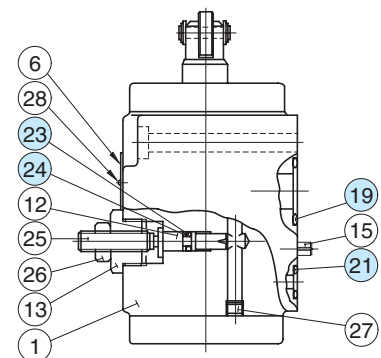

### List of Seals

Item	Name of Parts	Part Numbers			Qty.
		ZG ZCG-03	ZG ZCG-06	ZG ZCG-10	
18	O-Ring	SO-NB-P32	SO-NB-P36	SO-NB-P49	2
19	O-Ring	SO-NB-P18	SO-NB-P28	SO-NB-P32	2
20	O-Ring	SO-NA-P20	SO-NA-P25	SO-NA-P32	1
21	O-Ring	SO-NB-P9	SO-NB-P14	SO-NB-P14	1
22	O-Ring	SO-NB-P12	SO-NB-P18	SO-NB-P22A	1
23	O-Ring	SO-NA-P5	SO-NA-P5	SO-NA-P5	1
24	Back Up Ring	SO-BB-P5	SO-BB-P5	SO-BB-P5	1

Note: When ordering the seals, please specify the seal kit number from the table right.

### List of Seal Kits

Valve Model Numbers	Seal Kit Numbers
ZG-03	KS-ZG-03-22
ZG-06	KS-ZG-06-22
ZG-10	KS-ZG-10-22
ZCG-03	KS-ZCG-03-22
ZCG-06	KS-ZCG-06-22
ZCG-10	KS-ZCG-10-22