

Oilgear Towler

VC★.
CHECK VALVES.

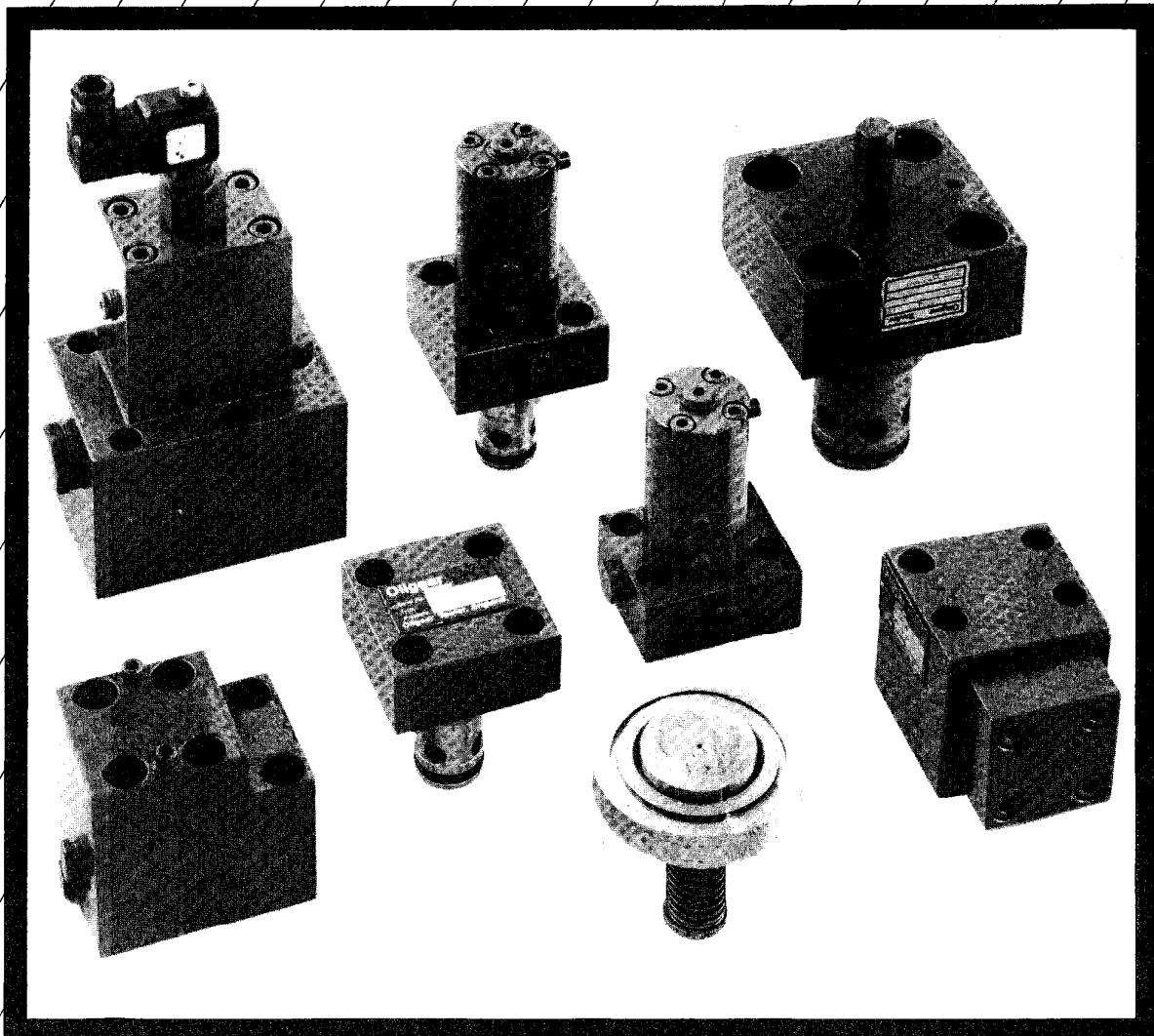

Bulletin 80104

PERFORMANCE ASSURANCE IS STANDARD WITH EVERY OILGEAR TOWLER COMPONENT AND SYSTEM.

Every Oilgear Towler check valve manufactured is shipped with a corporate commitment to support the component until it performs as specified.

This total dedication to performance is based upon experience gained since 1921 in matching fluid power equipment to a tremendous variety of machines and applications.

Performance Assurance is made possible because of experience gained over the years in supplying machinery builders and users with unique solutions to thousands of unusual fluid power problems.

Historically, Oilgear Towler has concentrated its energies on hydraulic equipment and systems. Every facility is staffed with factory trained and field experienced application engineers.

Performance Assurance doesn't stop with the design of the system or the sale of the component. Oilgear Towler engineers will be there, when they are needed, supplying the technical support, field service, parts and repairs, to make sure each component or system operates correctly.



You the customer and user of the equipment, have a vital role to play in ensuring that components and systems are installed, operated and maintained in accordance with our recommendations. By doing this you will help us to achieve Performance Assurance, to our mutual benefit.

A major cause of damage to any system or component is FLUID CONTAMINATION. We take great care in specifying filtration in systems we design and for individual components. You are requested to consult our bulletin "General Guidelines for Filtration and Contamination" and contact us if you have any questions.

Data and information in this document may be changed at any time without notification, to incorporate new developments.

You are strongly recommended to check with Oilgear Towler that you have up-to-date information when designing with, specifying or purchasing equipment.

The final selection of components for use in systems and compliance with all operational, performance and safety requirements is the responsibility of the user.



VC*
CHECK VALVES
STANDARD AND TRADITIONAL FOR PRESSURES
UP TO 1400 BAR.

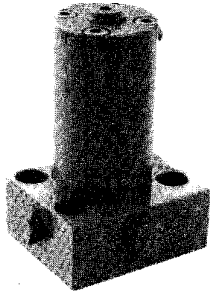

Internationally known as a world class hydraulics company, Oilgear Towler specialises in the design, engineering technology and equipment needed to solve difficult hydraulic problems by supplying the right components to meet specific needs.

This wide range of check valves is part of Oilgear Towler extensive range of hydraulic components. Collectively they present a range of valves from which to choose. Individually, each has a distinct application advantage.

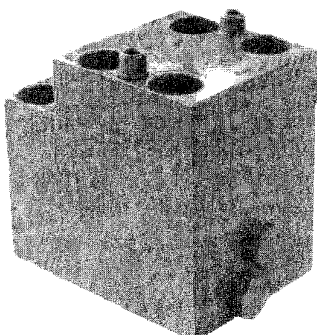
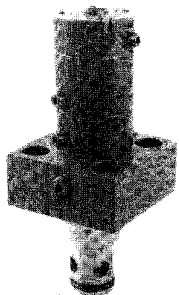
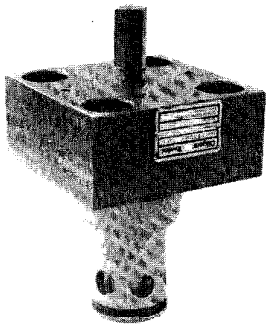

CONTENTS

PAGE

STANDARD RANGE

Design Features	4 - 5
VC* (Basic)	
Cartridge ISO7368	6 - 7
VC* (Pilot Operated)	
Cartridge ISO7368	
Manifold ISO5781	8 - 9
VCA (Headed Type)	
Manifold ISO5781	10 - 11
VCH (Flow Indicator)	
Manifold ISO5781	12 - 13
VCC (Traditional Range)	14 - 15
VCC (High Pressure Range)	16 - 18

ANCILLARIES

Manifold Conversion Blocks	
Specially Designed Blocks to convert ISO Cartridge Valves into Manifold Versions	19

VC* (Prefill Type)	20 - 21
---------------------------	---------

DIMENSIONAL DATA

General Overall Dimensions with Mounting Patterns and Centres	22 - 31
---	---------

VC★ CHECK VALVES DESIGN FEATURES.

In addition to the conventional check valve design, Oilgear Towler have available two other types, the headed check valve based upon pump technology and the prefill type check valve based on hydraulic press system technology. All three Types have features which have been proved over many years on a variety of hydraulic fluids, and all three types are arranged so that seats are controlled in width for optimum sealing and life. Various spring loads are available to suit individual application requirements, but best sealing is obtained with not less than 1 bar spring.

CONVENTIONAL DESIGN.

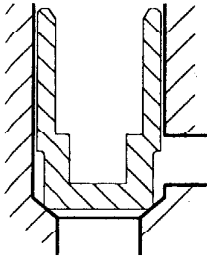

This is the design used in most applications and is far superior to the simple ball and spring where the ball can rotate, after the formation of a seat, and then leak because the new ball position is no longer offering a full seat. The valve type shown here can only rotate around the centre line and so seating remains positive. In addition the inherent advantage of precision machining of seats ensures that in service the controlled width of the seat is retained and therefore lifting pressure remains constant throughout the life of the valve. The larger area available in the spring cavity and the long guide with small clearances ensures good seating.

This type of design has the advantage that additions can easily be incorporated as shown on page 5.

HEADED TYPES.

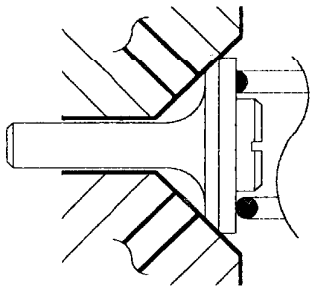

The valves shown have been the part of Oilgear Towler technique for many years and have proved to be more capable of retaining leak free operation better than any other design type. The technology is used with Oilgear Towler seated valve pumps which are renowned for long life, and if consideration is given to the number of cycles a valve within a pump is expected to survive, it is then possible to appreciate the efficiency and reliability of this design.

Based on pump discharge valve technology this type of valve will seat correctly, very quickly, and without damage. The spring load is transmitted axially as the spring is located as near to the seat as possible and cannot tilt the valve as easily as the conventional design. The small diameter stem guides the valve to its correct seating position, with friction and alignment characteristics being much improved over those encountered in the conventional design. A characteristic of this design is the low pressure rise above cracking pressure as flow increases, as the valve is almost balanced, unlike the conventional design which has a large ratio between the top cavity and the seat areas.

Because of these advantages, these valves have proved to give superior performance in systems using low viscosity fluids such as 95/5 at high pressures.

These valves are however restricted to the smaller sizes.

PREFILL TYPES.

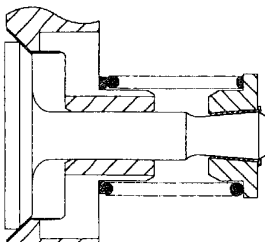

These valves retain all the advantages of the headed type but are used for larger flows. The design on which they are based is used in its smallest form as suction valves in Oilgear Towler seated valve pumps and in its larger form as prefill valves. As the valves are of large diameter, with restriction on spring parameters, differential pressures due to spring load can only be offered in the low range of 1 Bar. Consult Oilgear Towler for other pressure requirements.

VC*
CHECK VALVES
DESIGN FEATURES.

CONVENTIONAL DESIGN.

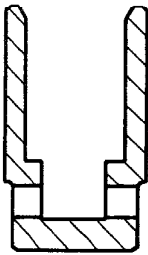

Standard poppet with internal balance for use with all applications.

CODE C (Box 3)

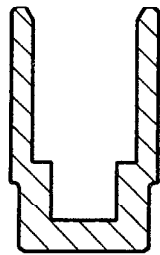

Standard poppet, not normally supplied by Oilgear Towler Leads, requires external drilling's to connect correctly.

CODE A (Box 3)

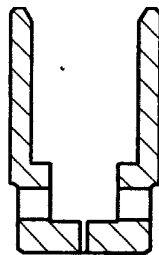

Standard poppet with bypass orifice.

CODE C (Box 3)
 CODE F (Box 10)

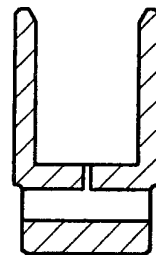

Pilot Operated poppet with feed from downstream annulus to balance area.

CODE V (Box 3)

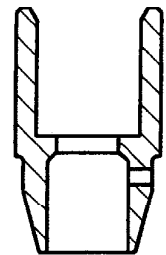

Reflux poppet specially designed for restricted closing.

CODE R (Box 3)

The conventional type also comes with different options for the Top Cap Assembly.

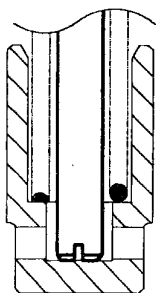

Standard poppet with adjustable lift, used for controlling the flow by restricting the valve opening.

CODE A (Box 10)

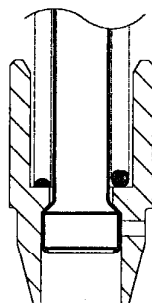

Reflux valve used for restricting the closing position of the valve.

CODE R (Box 3)

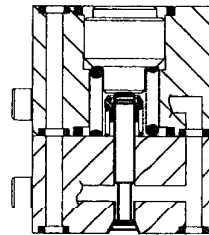

Pilot operated.

CODE V (Box 3)

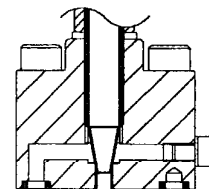

Bypass orifice externally adjustable.

CODE B (Box 10)

VC* - **C
CHECK VALVES (BASIC)
SLIP IN CARTRIDGE TO ISO7368.

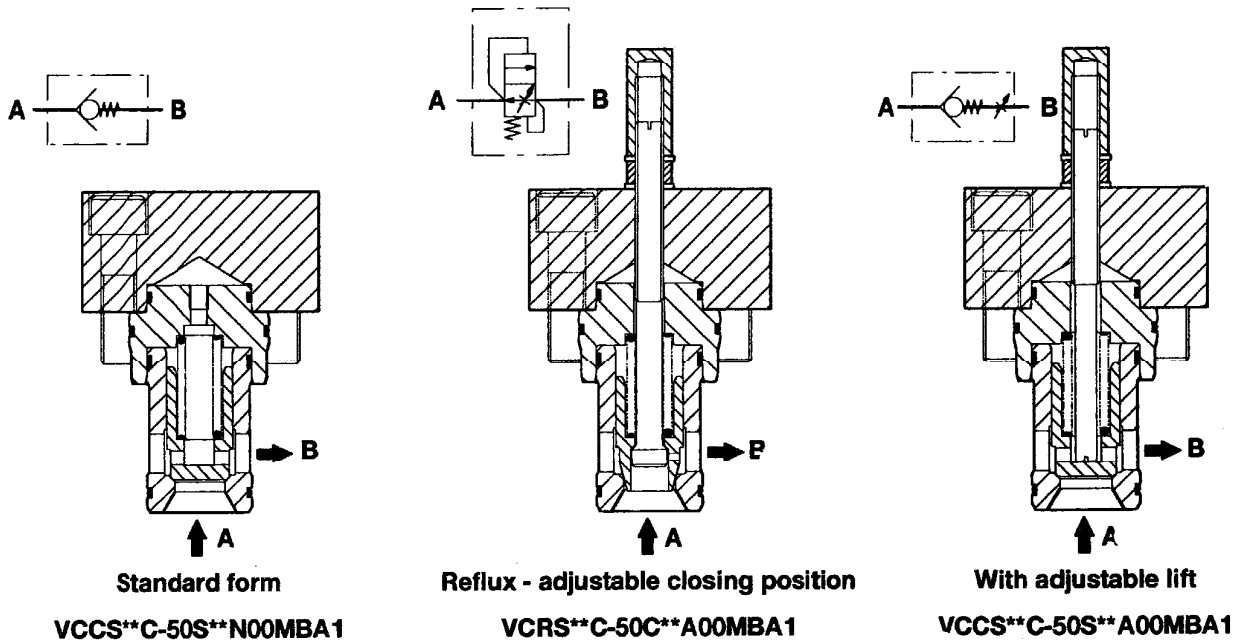

All testing generally in accordance with BS4062 part 1. "Fluid" - mineral oil, 32 centistokes at 40°C.

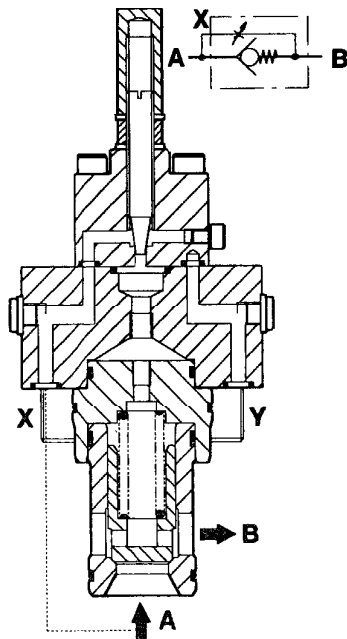

With adjustable bypass orifice
VCCSC-50S**B00MBA1**

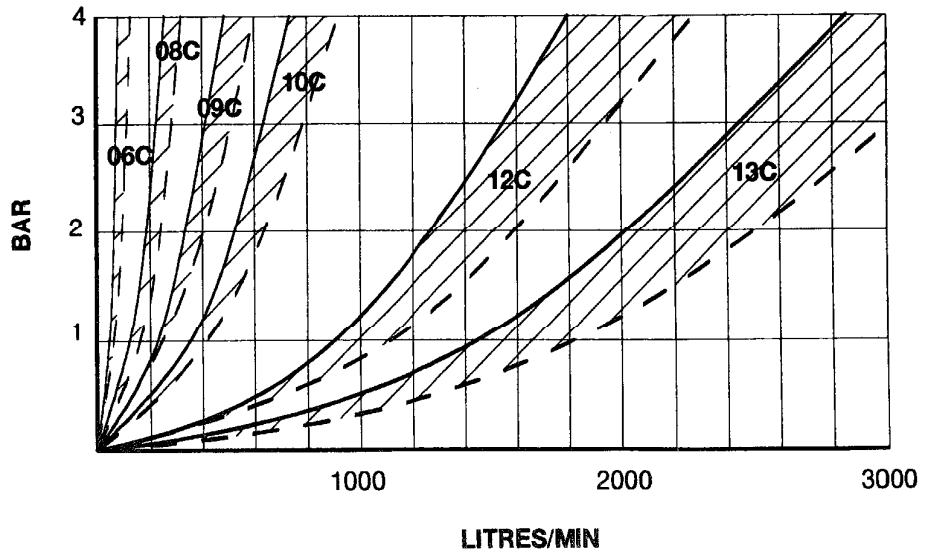

————— Valve complete including block

VC* - **C

**CHECK VALVES (BASIC)
SLIP IN CARTRIDGE TO ISO7368.
HOW TO ORDER.**

Block Number Explanation	1	2	3	4	5	6		7	8	9	10	11	12	13	14
Valve Example	V	C	*	S	**	*	—	**	*	**	*	**	M	*	A1

1 UNIT

V Valve

2 BASIC FORM

C Check

3 VALVE TYPE

C Check valve - balance chamber drilled in poppet

R Reflux (adjustable closing - locknut)

4 VALVE DESIGN

S Sliding poppet and metal seats

5 NOM SIZE

06 12

08 13

09 14

10

6 MOUNTING PATTERN

C Slip in cartridge to ISO 7368

CA As "C" with larger bolts (size 13)

7 MAX WORKING PRESSURE

Size	Code	Bar
06C	50	500
08C	50	500
09C	50	500
10C	50	500
12C	50	500
13C	45	450
13CA	50	500
14C	42	420

8 POPPET AND SLEEVE VARIATION.

S Standard no cushion

C Cushion nose

9 SPRING LOAD AT CRACKING

03 0.3 Bar

05 0.5 Bar

10 1.0 Bar

15 1.5 Bar

A0 10.0 Bar

00 No spring 0 pressure

10 TOP CAP ASSEMBLY

N No adjustment

A Adjustable lift (locknut)

B Bypass orifice - variable - (locknut)

F Bypass orifice - fixed - in poppet

P Bypass orifice - fixed - in poppet with adjustable lift (locknut)

11 ORIFICE SIZE

00 No orifice size

01 0.1 mm

10 1.0 mm

99 9.9 mm

The orifice sizes are mm x 10

12 DIMENSIONS

M Metric

13 SEALS

B Buna

V Viton

E E.P.D.M

Z Special

14 DESIGN SERIES

VCP, VCV - **P OR C
CHECK VALVES (PILOT OPERATED).

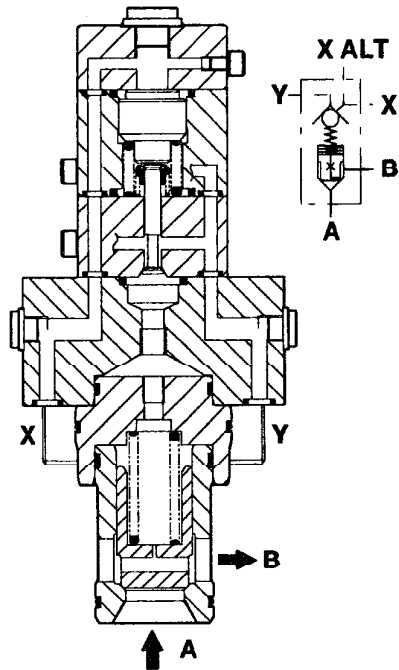

Two stage - Pilot operated
VCVSC-50S**N12MBA1**

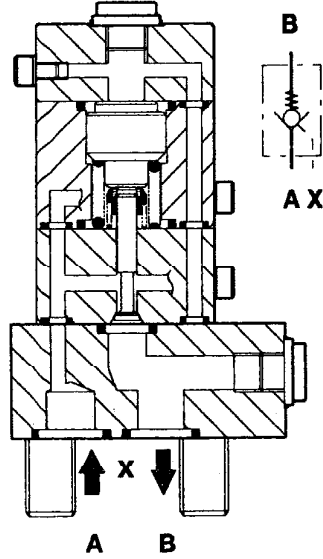

Pilot operated check
VCPS06P-31SN12MBA1**

All testing generally in accordance with BS4062 part 1. "Fluid" - mineral oil, 32 centistokes at 40°C.

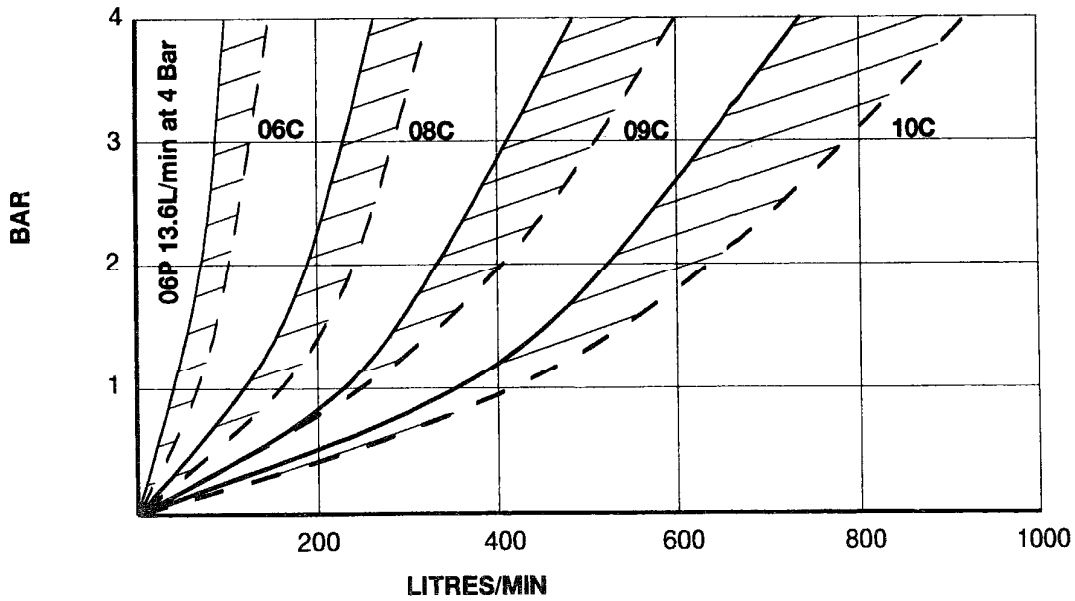

————— Valve complete including block

VCP, VCV - **P OR C

CHECK VALVES (PILOT OPERATED)

HOW TO ORDER.

Block Number Explanation	1	2	3	4	5	6		7	8	9	10	11	12	13	14
Valve Example	V	C	*	S	**	*	—	**	S	**	N	12	M	*	A1

1 UNIT

V Valve

2 BASIC FORM

C Check

3 VALVE TYPE

P Pilot operated - push piston

V Pilot operated - 2 stage by vent main poppet

4 VALVE DESIGN

S Sliding poppet and metal seats

5 NOM SIZE

SLIP IN CARTRIDGE MANIFOLD

06 **06**

08

09

10

6 MOUNTING PATTERN

C Slip in cartridge to ISO 7368

P Manifold mounting to ISO 5781

7 MAX WORKING PRESSURE

31 310 Bar (Manifold)

50 500 Bar (Cartridge)

8 POPPET AND SLEEVE VARIATION.

S Standard no cushion

9 SPRING LOAD AT CRACKING

03 0.3 Bar

05 0.5 Bar

10 1.0 Bar

15 1.5 Bar

A0 10.0 Bar

00 No spring 0 pressure

10 TOP CAP ASSEMBLY

N No adjustment

11 PILOT OPERATED VALVE RATIO

12 12 to 1

12 DIMENSIONS

M Metric

13 SEALS

B Buna

V Viton

E E.P.D.M

Z Special

14 DESIGN SERIES

A1 Assigned by factory

VCA - **P
CHECK VALVES (HEADED TYPE)
MANIFOLD MOUNTING TO ISO5781
FOR USE WITH HWBF FLUIDS.

This particular type of valve has been developed primarily for use with H.W.B.F, the main advantage being in the design of the main headed poppet and the guide arrangement. (See page 4).

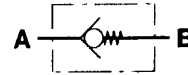
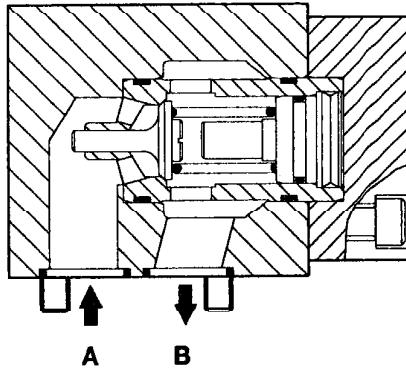
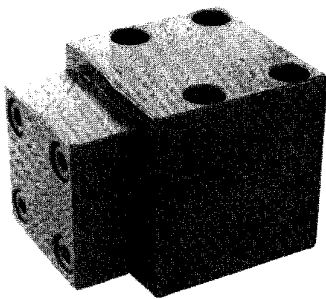

Standard Headed type check
VCATP-31S**N00MBA1**

All testing generally in accordance with BS4062 part 1. "Fluid" - 95/5 micro emulsion at 1 centistoke at 30°C

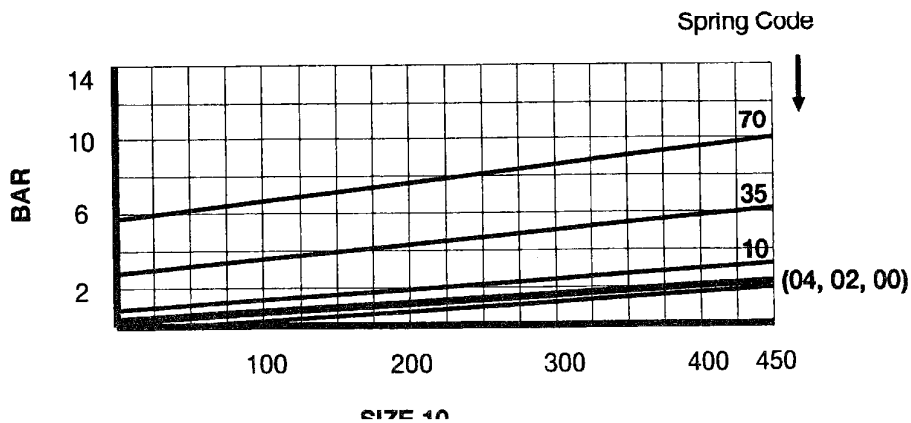
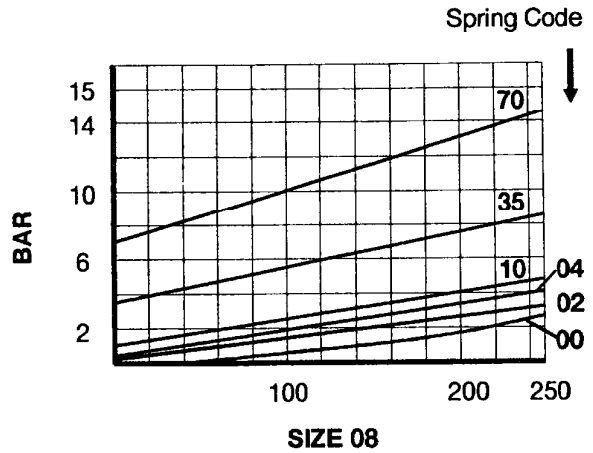
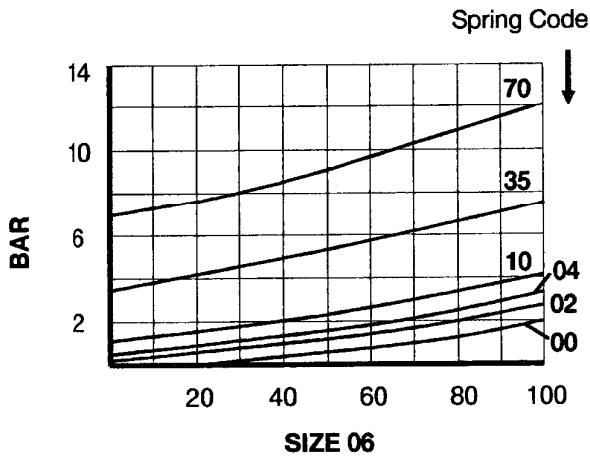

VCA - **P
CHECK VALVES (HEADED TYPE)
MANIFOLD MOUNTING TO ISO5781
FOR USE WITH HWBF FLUIDS.

Block Number Explanation	1	2	3	4	5	6		7	8	9	10	11	12	13	14
Valve Example	V	C	A	T	**	P	—	31	S	**	N	00	M	*	A1

1 UNIT

V Valve

2 BASIC FORM

C Check

3 VALVE TYPE

A Check valve

4 VALVE DESIGN

T Headed valve stem guide up stream
spring on head

5 NOM SIZE

06

08

10

6 MOUNTING PATTERN

P Manifold mounting to ISO 5781

7 MAX WORKING PRESSURE

31 310 Bar (Manifold)

8 POPPET AND SLEEVE VARIATION.

S Standard no cushion

9 SPRING LOAD AT CRACKING

03 0.3 Bar

05 0.5 Bar

10 1.0 Bar

15 1.5 Bar

A0 10.0 Bar

00 No spring 0 pressure

10 TOP CAP ASSEMBLY

N No adjustment

11 ORIFICE SIZE

00 No orifice size

12 DIMENSIONS

M Metric

13 SEALS

B Buna

V Viton

E E.P.D.M

Z Special

14 DESIGN SERIES

A1 Assigned by factory

VCH - **P CHECK VALVES (FLOW INDICATOR).

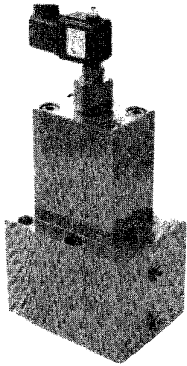

The Flow indicator valve is used within a system to detect that flow is passing through that part of the circuit. They are regularly used on complex sustain type systems to detect hose or pipe failure. When flow passes from A to B the valve will lift and the switch will indicate that flow is passing, but at this stage the (failure) signal is ignored. When the cylinder reaches its sustain or clamp position, flow will stop and the valve will close, the switch indicating closed. However, in order to maintain pressure in the cylinder, and to overcome any small leakages downstream of the valve, a small flow can pass over the orifice without causing the valve to lift and actuate the electrical signal. Any increase in leakage over this set level, such as a burst hose will give a signal. The valve should ideally be installed in the circuit prior to any fault area, and so avoiding false signals caused by other valves operating.

The valve is arranged so that flow can pass from B to A with less restriction, and no signal is given.

The switch should always be installed so that a broken wire will indicate a fault.

All testing generally in accordance with BS4062 part 1. "Fluid" - mineral oil, 32 centistokes at 40°C.

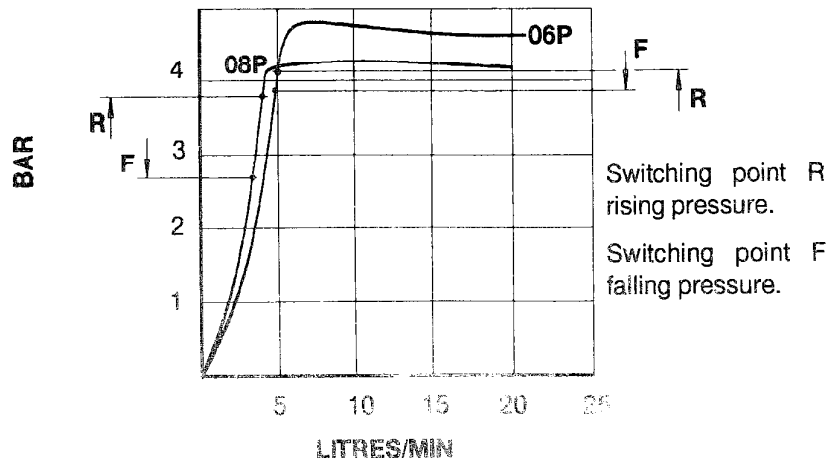
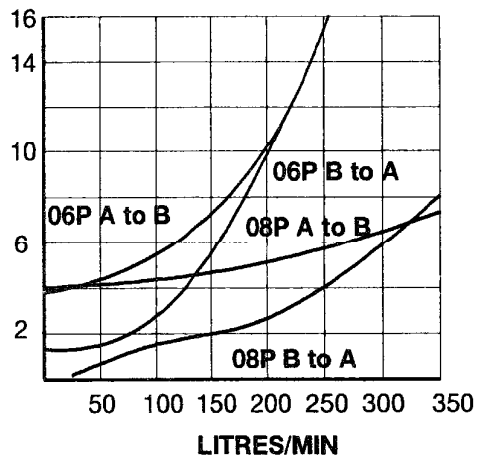
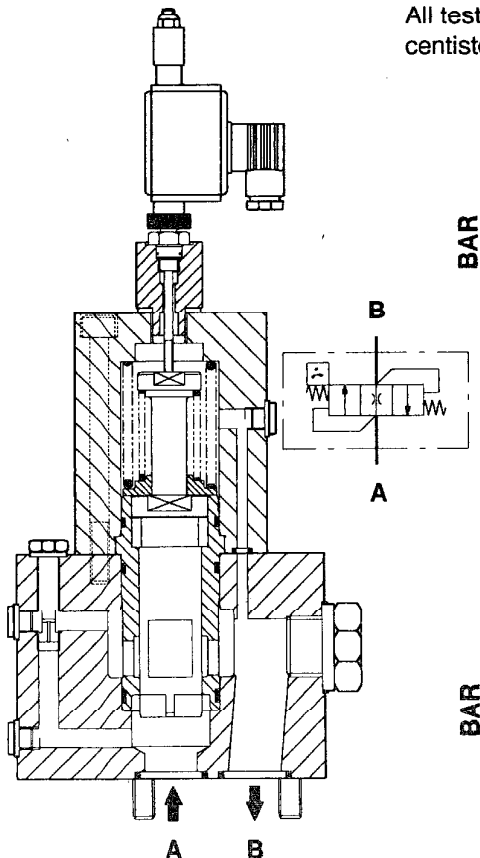

Flow switch. Switch operates with rising spool. Flow A to B.

VCHN**P-31S35T**MBA1

VCH - **P
CHECK VALVES (FLOW INDICATOR)
HOW TO ORDER.

Block Number Explanation	1	2	3	4	5	6		7	8	9	10	11	12	13	14
Valve Example	V	C	H	N	**	P	—	31	S	35	T	**	M	*	A1

1 UNIT

V Valve

2 BASIC FORM

C Check

3 VALVE TYPE

H Flow indicator with reserve flow feature

4 VALVE DESIGN

N Sliding poppet no seat - metal lap

5 NOM SIZE

06

08

6 MOUNTING PATTERN

P Manifold mounting to ISO 5781

7 MAX WORKING PRESSURE

31 310 Bar (Manifold)

8 POPPET AND SLEEVE VARIATION.

S Standard no cushion

9 SPRING LOAD AT CRACKING A TO B

35 3.5 Bar

10 TOP CAP ASSEMBLY

T Induction switch - fixed orifice in body

11 ORIFICE SIZE

00 No orifice size

10 1.0 mm

20 2.0 mm (As normally supplied)

99 9.9 mm

The orifice sizes are mm x 10

12 DIMENSIONS

M Metric

13 SEALS

B Buna

V Viton

E E.P.D.M

Z Special

14 DESIGN SERIES

A1 Assigned by factory

VCC - **T ORE
CHECK VALVES (TRADITIONAL RANGE)
HOUSE STANDARD MOUNTING.

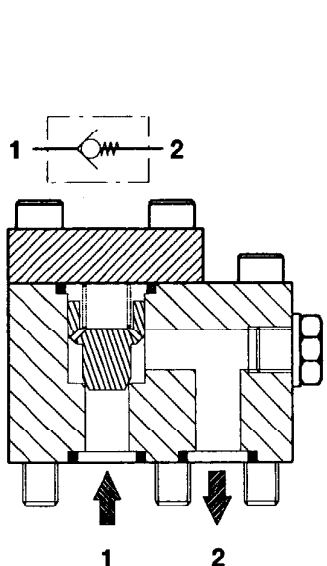

Traditional Range
VCCSE-A2S**N00KBA1**

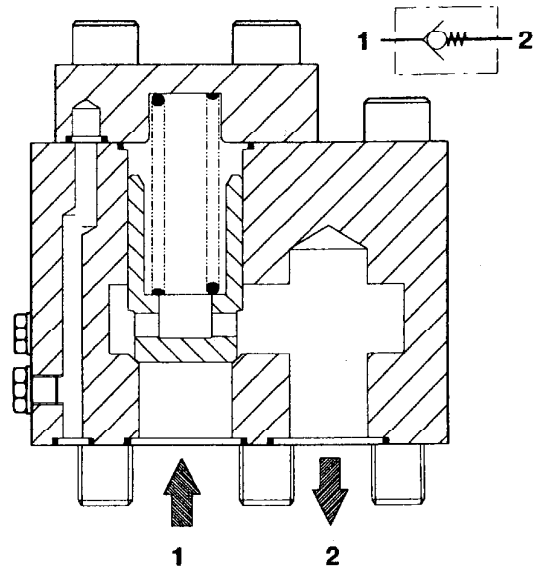

Traditional Range
VCCST-48S**N00KBA1**

All testing generally in accordance with BS4062 part 1. "Fluid" - mineral oil, 32 centistokes at 40°C.

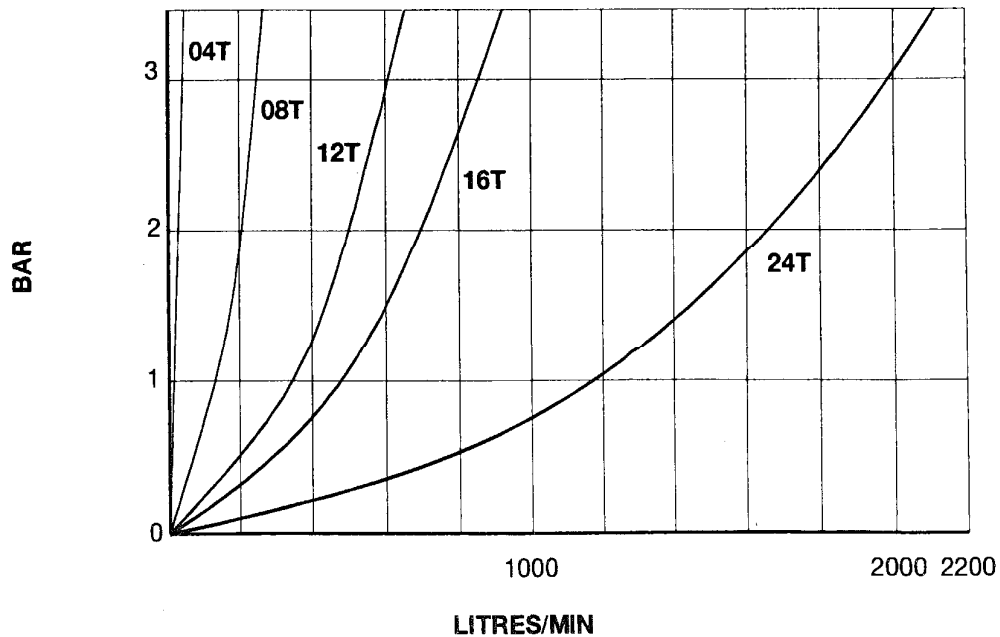

VCC - **T OR E
CHECK VALVES (TRADITIONAL RANGE)
HOUSE STANDARD MOUNTING.
HOW TO ORDER.

Block Number Explanation	1	2	3	4	5	6		7	8	9	10	11	12	13	14
Valve Example	V	C	C	S	**	*	—	**	S	**	*	**	K	*	A1

1 UNIT

V Valve

2 BASIC FORM

C Check

3 VALVE TYPE

C Check valve - balance chamber drilled in poppet

4 VALVE DESIGN

S Sliding poppet and metal seats

5 NOM SIZE

04 16

08 24

12

6 MOUNTING PATTERN

T Towler Traditional For 480 Bar

E Towler Traditional For 1200 Bar

7 MAX WORKING PRESSURE

48 480 Bar

A2 1200 Bar

8 POPPET AND SLEEVE VARIATION.

S Standard no cushion

9 SPRING LOAD AT CRACKING

03 0.3 Bar

05 0.5 Bar

10 1.0 Bar

15 1.5 Bar

A0 10.0 Bar

00 No spring 0 pressure

10 TOP CAP ASSEMBLY

N No adjustment

A Adjustable lift (locknut)

B Bypass orifice - variable - (locknut)

F Bypass orifice - fixed - in poppet

11 ORIFICE SIZE

00 No orifice size

01 0.1 mm

10 1.0 mm

99 9.9 mm

The orifice sizes are mm x 10

12 DIMENSIONS

K U.K inch + metric fixing bolts

13 SEALS

B Buna

V Viton

E E.P.D.M

Z Special

14 DESIGN SERIES

A1 Assigned by factory

VCC - **B
CHECK VALVES
HIGH PRESSURE HOUSE STANDARD CARTRIDGE
700 BAR WORKING PRESSURE.

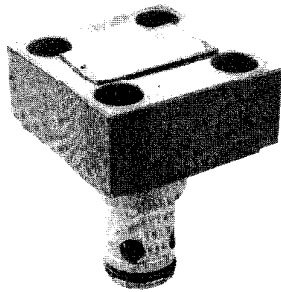

Due to design and stress limitations those valves based on the standard cartridge centres ISO 7368 are only capable of a safe working pressure of 480 Bar.

For working pressures higher than this Oilgear Towler have introduced a small range of valves capable of working at 700 Bar. They are still based on ISO 7368 but combine the cartridge bore element from one size with the bolt centres and drilling's from the size above.

This combination gives a safe unit for working at these higher pressures whilst still maintaining the flexibility of using various poppet designs from the standard range of VCC valves.

For economic reasons this particular range of valves have been limited to 3 sizes only 06, 08 and 09.

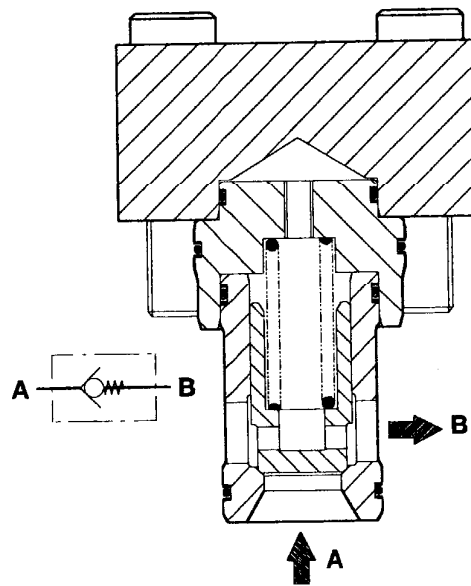

Standard High pressure form

VCCSB-70S**N00MBA1**

All testing generally in accordance with BS4062 part 1. "Fluid" - mineral oil, 32 centistokes at 40°C.

For flow and pressure drop data see graph on page 6.

VCC - **B, J OR JB
CHECK VALVES
HIGH PRESSURE HOUSE STANDARD CARTRIDGE
700 BAR WORKING PRESSURE
HOW TO ORDER.

Block Number Explanation	1	2	3	4	5	6		7	8	9	10	11	12	13	14
Valve Example	V	C	C	S	**	**	—	*	S	**	*	**	M	*	A1

1 UNIT

V Valve

2 BASIC FORM

C Check

3 VALVE TYPE

C Check valve - balance chamber drilled in poppet

4 VALVE DESIGN

S Sliding poppet and metal seats

5 NOM SIZE

06

08

09

6 MOUNTING PATTERN

B Slip in cartridge 700 Bar

JB Slip in cartridge 1000 Bar

J Slip in cartridge 1400 Bar

7 MAX WORKING PRESSURE

70 700 Bar

A0 1000 Bar

A4 1400 Bar

8 POPPET AND SLEEVE VARIATION.

S Standard no cushion

9 SPRING LOAD AT CRACKING

03 0.3 Bar

05 0.5 Bar

10 1.0 Bar

15 1.5 Bar

A0 10.0 Bar

00 No spring 0 pressure

10 TOP CAP ASSEMBLY

N No adjustment

A Adjustable lift (locknut)

F Bypass orifice - fixed - in poppet

11 ORIFICE SIZE

00 No orifice size

01 0.1 mm

10 1.0 mm

99 9.9 mm

The orifice sizes are mm x 10

12 DIMENSIONS

M Metric

13 SEALS

B Buna

V Viton

E E.P.D.M

Z Special

14 DESIGN SERIES

A1 Assigned by factory

VC* - **J OR JB
CHECK VALVES
HIGH PRESSURE HOUSE STANDARD CARTRIDGE
1400 BAR.

This form of check valve is used to control hydraulic systems with working pressures up to 1400 bar.

The mounting pattern is based on ISO7368 and contains elements of various sizes of valves combined together to give this particular high pressure range.

Due to the physical properties of the materials used the maximum size available is equivalent to a size 10 (N.G 40) giving a nominal flow capacity of 400 l/min at 3.5 bar.

CAVITY FOR UP TO 700 BAR

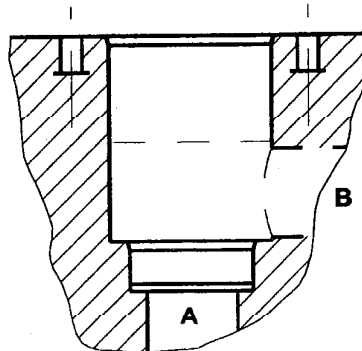

CAVITY FOR OVER 700 BAR

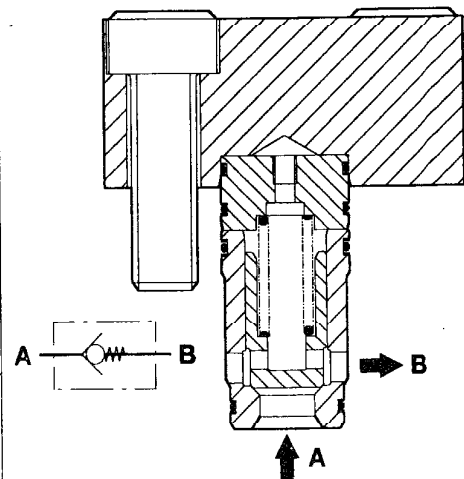
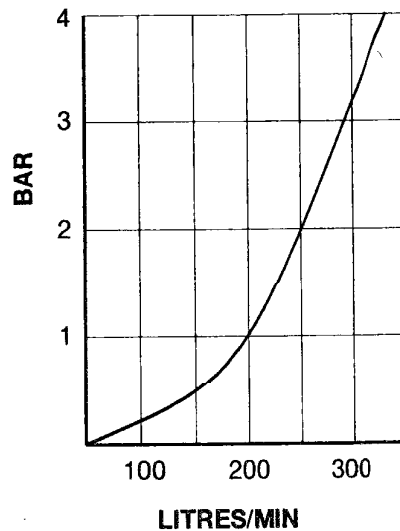
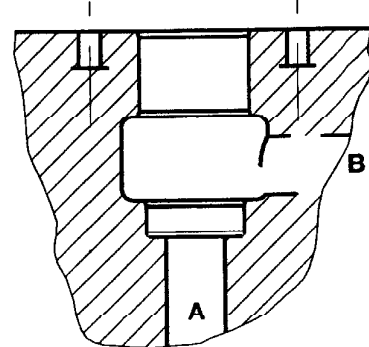

**High pressure standard
 cartridge valve**

VCCSJ-A4S**N**MBA1**

VC*
MANIFOLD CONVERSION BLOCKS
TO CONVERT CARTRIDGE MOUNTING ISO7368
TO MANIFOLD MOUNTING.

These blocks are used to convert standard cartridge valves of ISO7368 form into non-standard manifold mounting versions.

They are intended for use at higher pressures than are allowed by the standard manifold centres of ISO5781.

Oilgear Towler have produced these blocks with a view to easier manufacture of the mating manifold if boring facilities are limited. The precise machining of cartridge bores is no longer required so the manifold is simply a drilled component but with good surface finishes on mating faces.

All inter connecting drilling's are done in the conversion block and each port sealed using square section joint rings to minimise leakage. Pilot and drain ports are spaced at one end of the block for ease of drilling in main manifold. These blocks are only available for cartridge valves to ISO7368 and up to and including size 10 (NG40).

Oilgear Towler do not recommend the using of surface mounted valves for high pressures in sizes over 63mm.

Ports X, Y and Z2 are not required for basic check valve.

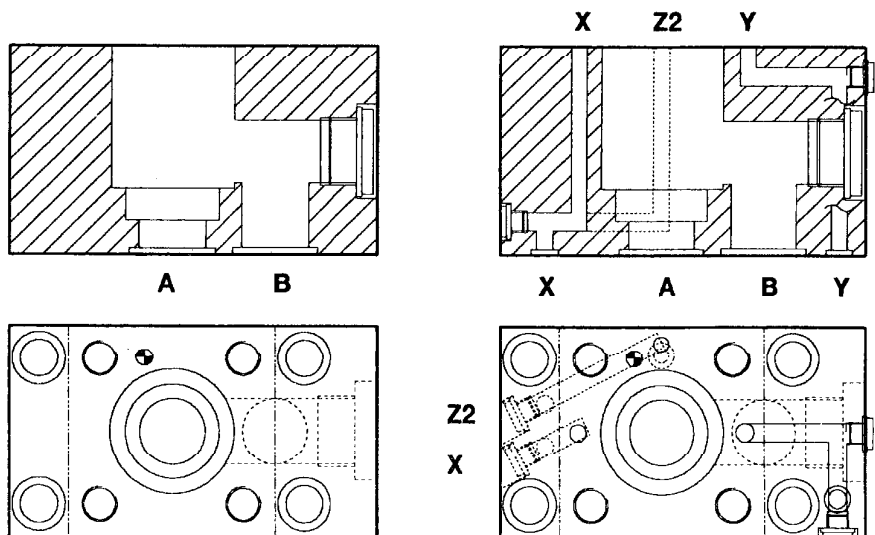

VC*
CHECK VALVES (PREFILL TYPE)
UP TO 700 BAR.

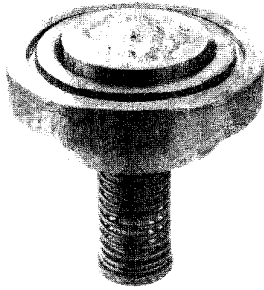

This particular type of check valve is used in positions where high flows are required with high pressure acting on both upstream and downstream lines.

They are available as a loose item for customers mounting or as part of a unit complete with flange to customers requirements.

The range of flows is up to 5000 l/min with a working pressure of 480 Bar.

Sizes up to 450 are possible, see Bulletin T86000 for flow ratings and sizes, for higher pressures consult Oilgear Towler.

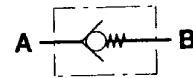
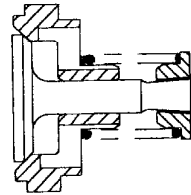

Insert Valve no housing

VCUUI**S10NNMNA1**

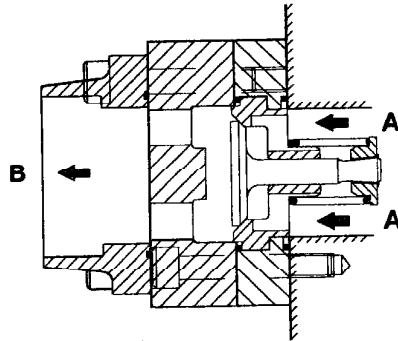

Face/line flow from face

VCAULC3**S10NNMBA1**

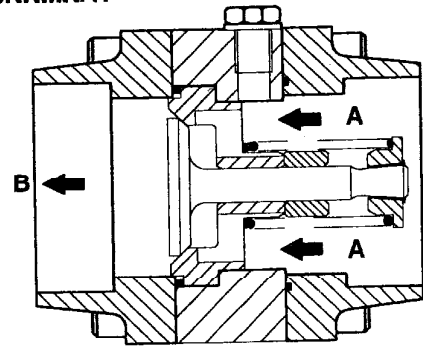

Line mounting flange 3000 series

VCAUL3**S10NNMBA1**

All testing generally in accordance with BS4062 part 1. "Fluid" - mineral oil, 32 centistokes at 40°C with standard springs fitted.

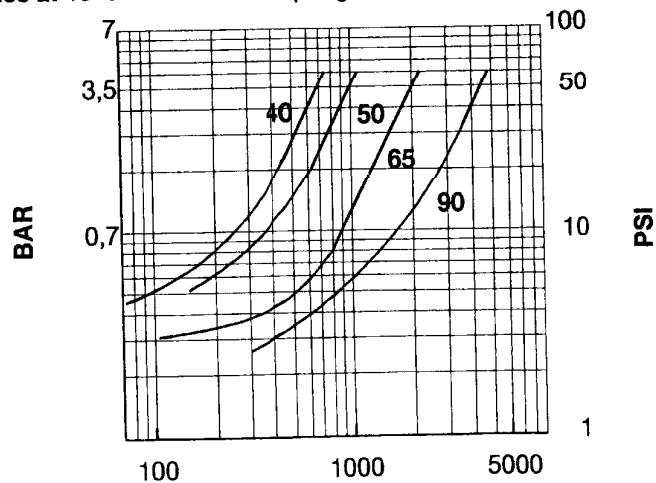

VC*
CHECK VALVES (PREFILL TYPE)
UP TO 700 BAR
HOW TO ORDER.

Block Number Explanation	1	2	3	4	5	6		7	8	9	10	11	12	13	14
Valve Example	V	C	*	U	**	***	—	**	S	10	N	N	*	*	A1

1 UNIT

V Valve

2 BASIC FORM

C Check

3 VALVE TYPE

A Check valve

U Seated check valve - bare assembly no housing

4 VALVE DESIGN

U Headed valve stem - guide up stream - spring on stem

5 NOM SIZE

40

50

65

90

6 MOUNTING PATTERN

LB	Line Mounting	BSP Tapping
L3	Line Mounting	Flange SAE 3000 Series
L6	Line Mounting	Flange SAE 6000 Series
LC3	Face/Line flow from face	Flange SAE 3000 Series
LC6	Face/Line flow from face	Flange SAE 6000 Series
LD3	Face/Line flow to face	Flange SAE 3000 Series
LD6	Face/Line flow to face	Flange SAE 6000 Series
I	Insert Valve - No housing	

7 MAX WORKING PRESSURE

21 210 Bar

50 500 Bar

70 700 Bar (Size 40, 50)

8 POPPET AND SLEEVE VARIATION.

S Standard no cushion

9 SPRING LOAD AT CRACKING

10 1.0 Bar

10 TOP CAP ASSEMBLY

N No adjustment

11 ORIFICE SIZE

N Not applicable

12 DIMENSIONS

M Metric

K U.K inch + metric fixing bolts

B Metric with BSP port threads

13 SEALS

B Buna

V Viton

E E.P.D.M

Z Special

N No seals

14 DESIGN SERIES

A1 Assigned by factory

GENERAL DIMENSIONAL DATA

VC*, VCC, VCH.

SLIP-IN CARTRIDGE VALVES VC*

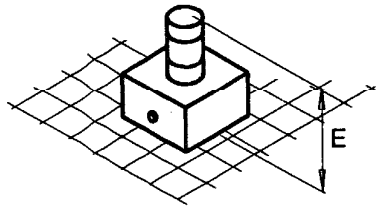
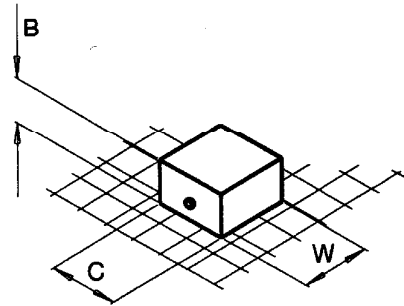
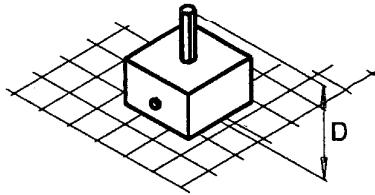
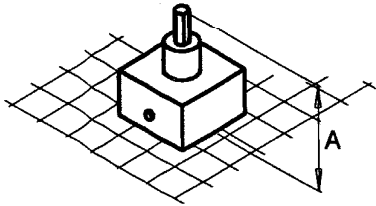

	A	B	C	D	E	W
06C	134	32	63,5	90	134	63,5
08C	142	40	89	98	142	89
09C	152	50	102	108	152	102
10C	152	50	127	108	152	127
12C	187	85	180	143	—	180
13C	—	100	—	∅250	—	—
13CA	—	100	—	∅250	—	—
14C	—	90	—	∅300	—	—

CHECK DIM TAB 1 7/12/93

TRADITIONAL VALVES VCC

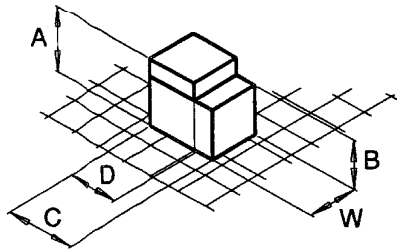

	A	B	C	D	W
04T	*63	51	76	51	51
08T	101	76	115	76	76
12T	140	108	156	122	111
16T	171	136	187	130	120
24T	222	165	230	152	190
04E	*70	51	80	55	70
08E	114	82,5	119	89	102
12E	175	117	165	140	140

CHECK DIM TAB 2 7/12/93

* ADD 20mm FOR 7 BAR SPRING

FLOW SWITCH VALVES VCH

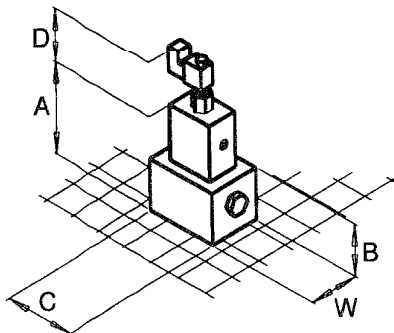

	A	B	C	D	W
06P	186	88,9	120	103	88,9
08P	208	100	140	103	100

CHECK DIM TAB 3 7/12/93

GENERAL DIMENSIONAL DATA

VC*, VCA.

MANIFOLD PILOT OPERATED VALVES VC*

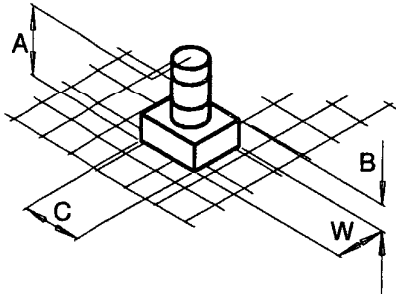

	A	B	C	W
06P	139	37	88,9	76,2

CHECK DIM TAB 4 7/12/93

MANIFOLD H.W.B.F VALVES VCA

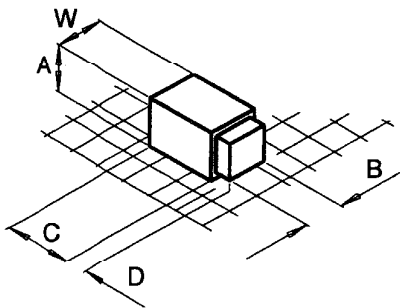

	A	B	C	D	W
06P	88,9	70	85	35	88,9
08P	100	88,9	110	38	100
10P	127	115	140	50	120

CHECK DIM TAB 5 7/12/93

PREFILL TYPE VALVES VC* SAE FLANGES

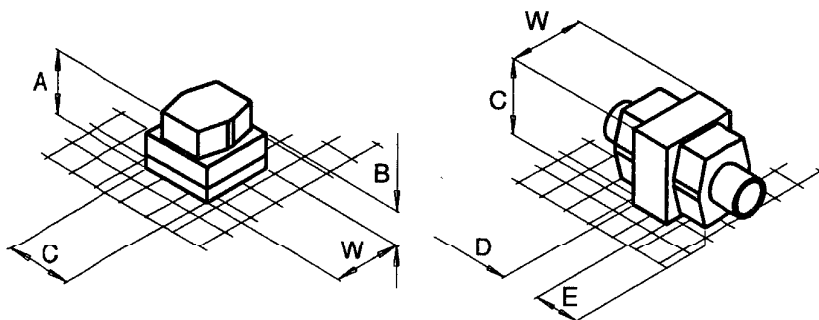

	A	B	C	D	E	W
50	115	65	127	40	50	127
90	211	163	180	—	—	170

CHECK DIM TAB 6 7/12/93

MOUNTING PATTERN
CHECK VALVES
CARTRIDGE MOUNTING TO ISO7368
500 BAR
FOR VC★ - 06C TO 12C.

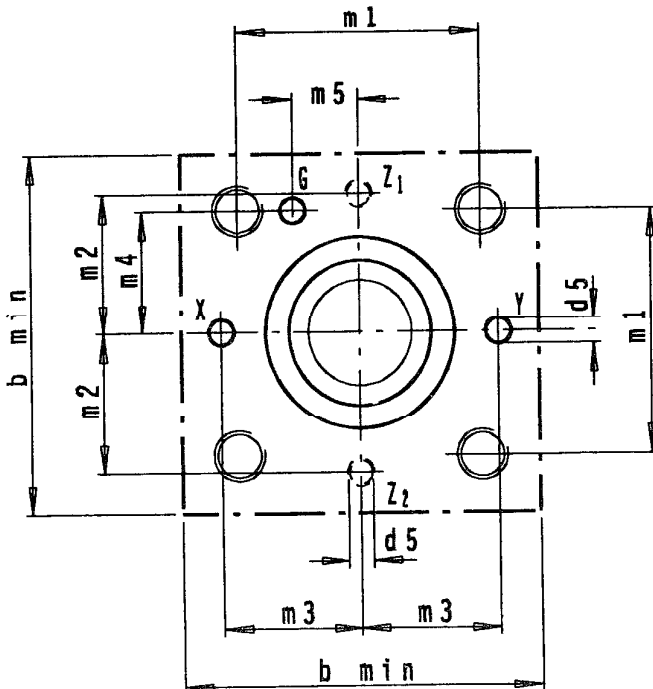
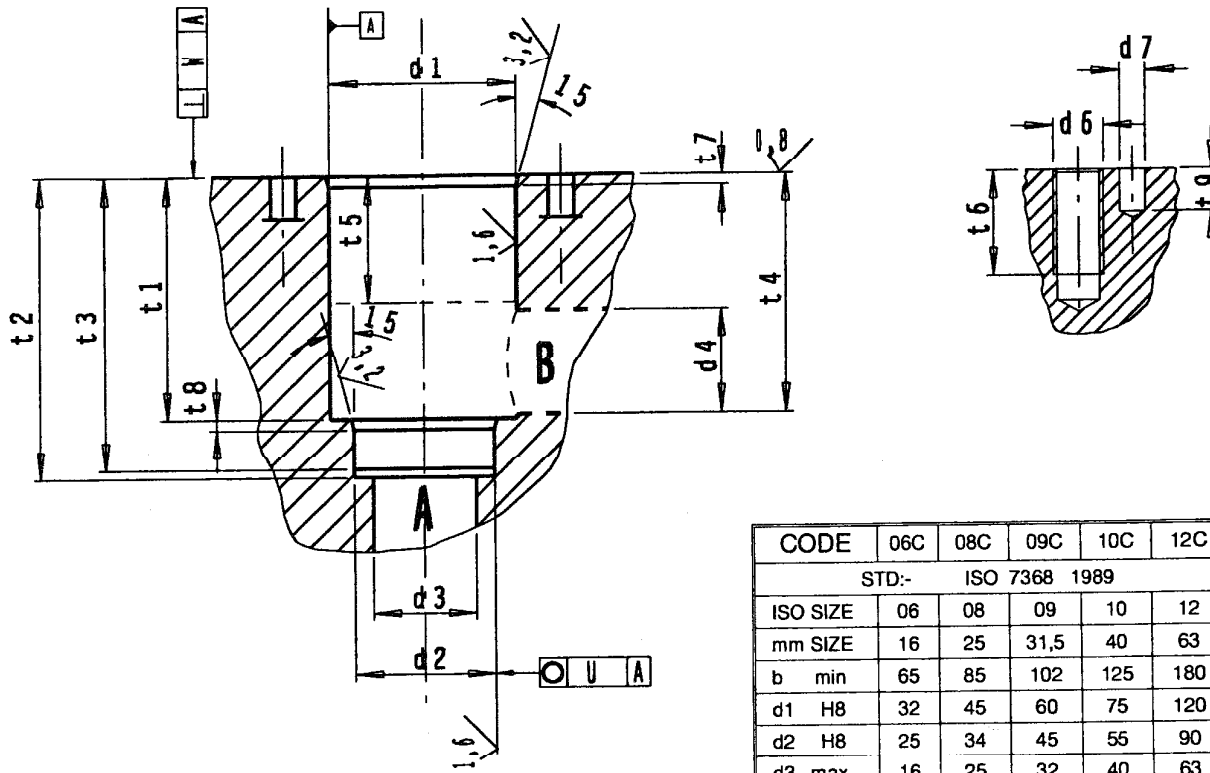

CODE	06C	08C	09C	10C	12C
STD:- ISO 7368 1989					
ISO SIZE	06	08	09	10	12
mm SIZE	16	25	31,5	40	63
b min	65	85	102	125	180
d1 H8	32	45	60	75	120
d2 H8	25	34	45	55	90
d3 max	16	25	32	40	63
d4	16	25	31,5	40	63
d5 max	4	6	8	10	12
d6	M8	M12	M16	M20	M30
d7 H13	4	6	6	6	8
m1 ±0,2	46	58	70	85	125
m2 ±0,2	25	33	41	50	75
m3 ±0,2	25	33	41	50	75
m4 ±0,2	23	29	35	42,5	62,5
m5 ±0,2	10,5	16	17	23	38
t1 +0,1	43	58	70	87	130
t2 +0,1	56	72	85	105	155
t3	54	70	83	102	150
t4 max	42,5	57	68,5	84,5	127
t5	20	30	30	30	40
t6 max	22	30	38	46	66
t7	2	2,5	2,5	3	4
t8	2	2,5	2,5	3	4
t9 min	8	8	8	8	8
U	0,03	0,03	0,03	0,05	0,05
W	0,05	0,05	0,1	0,1	0,2

MOUNTING PATTERN
CHECK VALVES
CARTRIDGE MOUNTING TO ISO7368
500 BAR
FOR VCC - 13C, 13CA AND 14C.

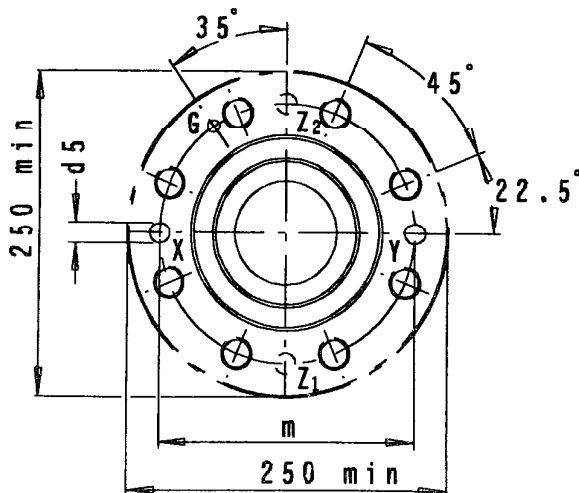
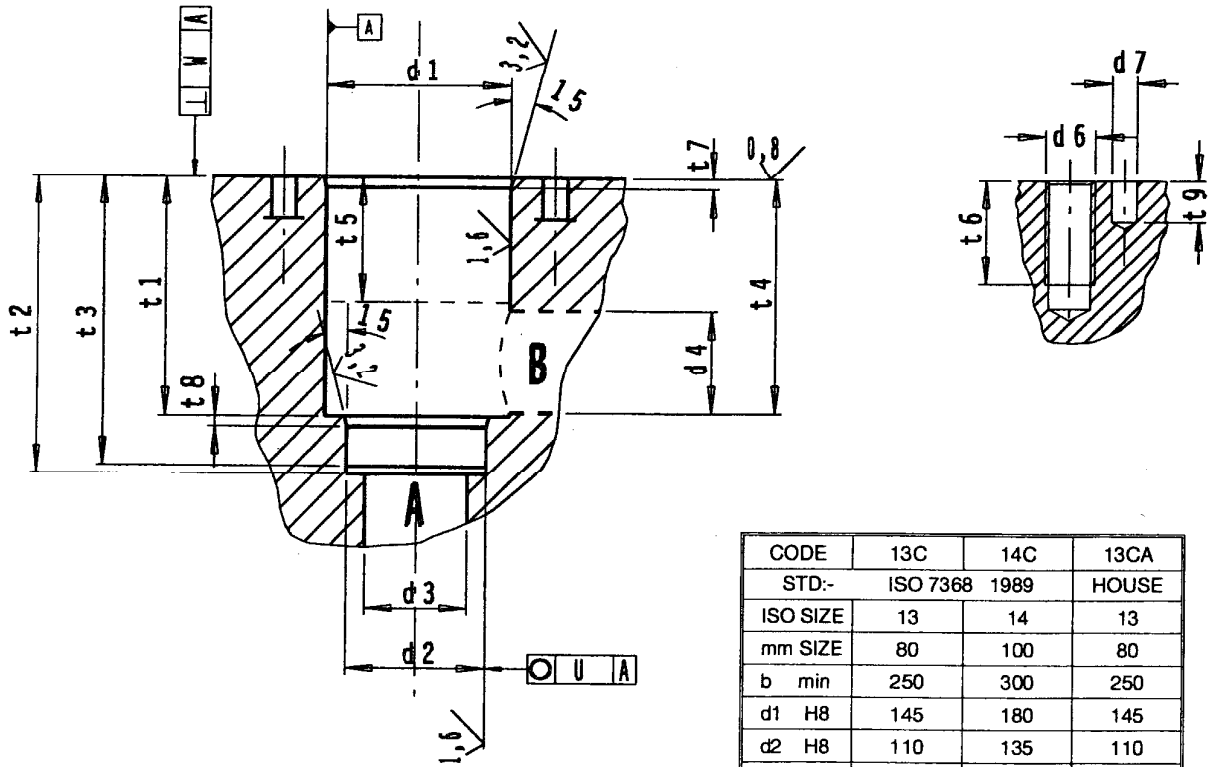

CODE	13C	14C	13CA
STD:-	ISO 7368	1989	HOUSE
ISO SIZE	13	14	13
mm SIZE	80	100	80
b min	250	300	250
d1 H8	145	180	145
d2 H8	110	135	110
d3 max	80	100	80
d4	80	100	80
d5 max	16	20	16
d6	M24	M30	M30
d7 H13	10	10	10
m ±0,2	200	245	200
t1 +0,2	175	210	175
t2 +0,2	205	245	205
t3	200	239	200
t4 max	170,5	205,5	170,5
t5	40	50	40
t6 max	54	66	54
t7	5	5	5
t8	5	5	5
t9 min	8	8	8
U	0,05	0,05	0,05
W	0,2	0,2	0,2

ISO7368c 6/3/93

**MOUNTING PATTERN
CHECK VALVES
MANIFOLD MOUNTING TO ISO5781
310 BAR
FOR VC* - **P.**

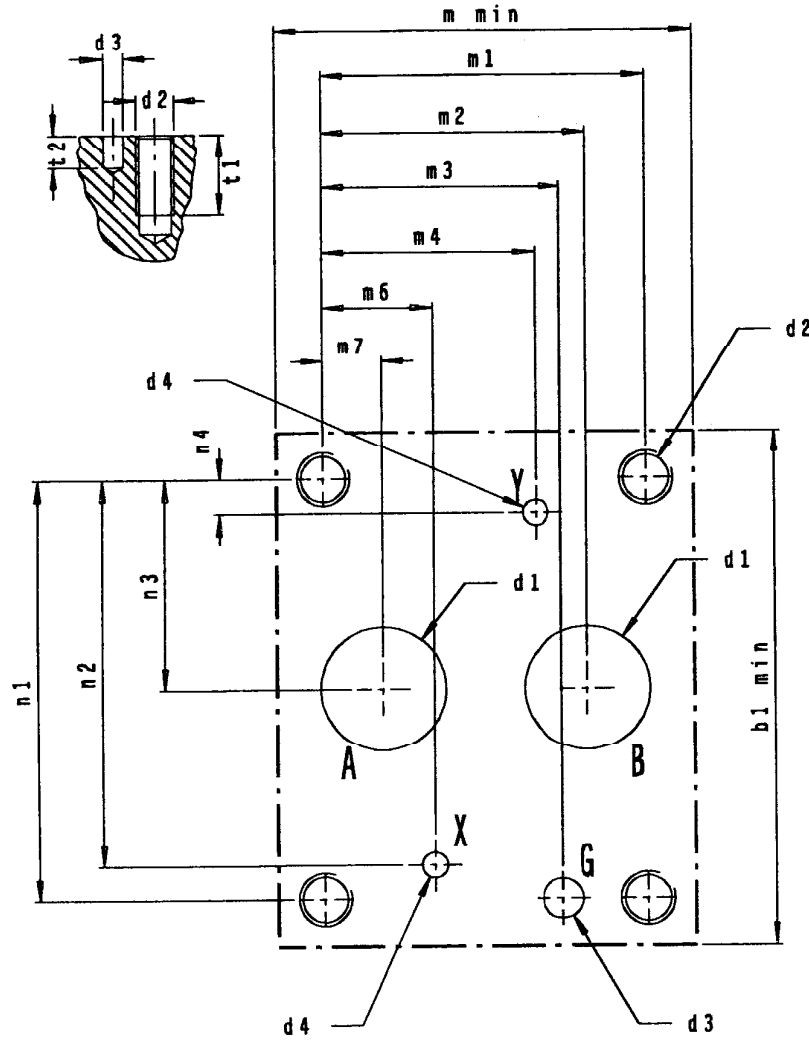

CODE / SIZE			STD:- ISO 5781 1987																		
O / T	ISO	mm	b min	d1 max	d2	d3	d4	m min	m1 ±0,1	m2 ±0,2	m3 ±0,1	m4 ±0,2	m5 ±0,1	m6 ±0,2	m7 ±0,2	n1 ±0,1	n2 ±0,2	n3 ±0,2	n4 ±0,2	t1	t2 min
06P	06	16	84	14,7	M10	7,5	4,8	61	42,9	35,7	31,8	21,4	—	21,4	7,1	66,7	58,7	33,3	7,9	26	8
08P	08	25	97	23,4	M10	7,5	4,8	78	60,3	49,2	44,5	39,7	—	20,8	11,1	79,4	73	39,7	6,4	26	8
10P	10	32	114	32	M10	7,5	4,8	102	84,1	67,5	62,7	59,5	42,1	24,6	16,7	96,8	92,9	48,4	4	26	8

**MOUNTING PATTERN
CHECK VALVES
HOUSE STANDARD MANIFOLD MOUNTING
480 - 1400 BAR
FOR VCC - ★★T OR G.**

SIZE 04

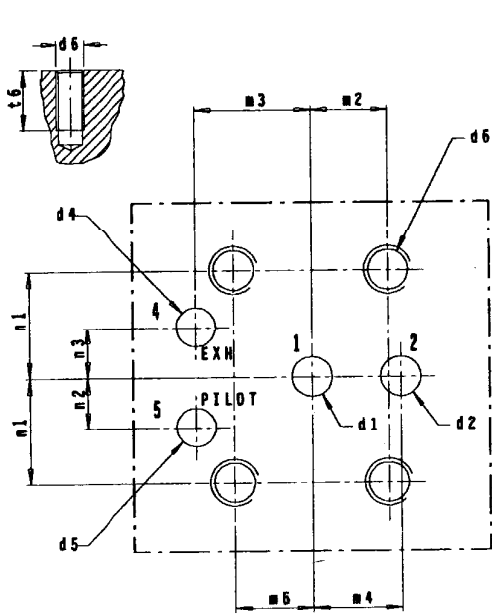

SIZE 08, 12, 16 AND 24

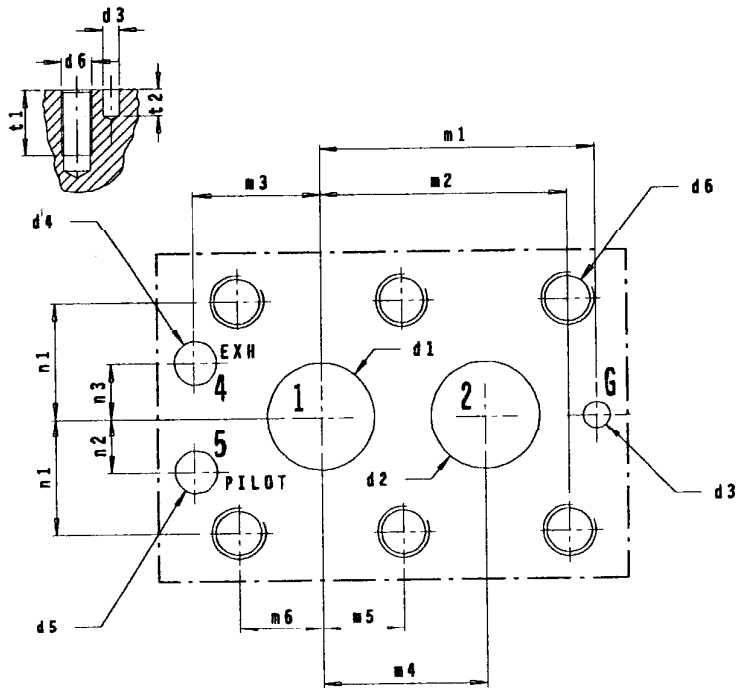

CODE / SIZE		W. P (BAR) max	STD:- HOUSE CK***																
O / T	mm		d1	d2	d3	d4	d5	d6	m1 ±0,1	m2 ±0,1	m3 ±0,2	m4 ±0,2	m5 ±0,1	m6 ±0,1	n1 ±0,1	n2 ±0,2	n3 ±0,2	t1 max	t2 min
04T	12	480	11	11	—	—	—	M10	—	42,1	—	31,75	16,7	16,7	16,7	—	—	15	—
08T	25	480	25	25	6	10	10	M12	63,5	57,2	28,6	38,1	19	19	27	12,7	12,7	20	6
12T	40	480	35	35	—	10	10	M16	—	79,4	44,5	50,8	34,9	34,9	41,3	20,6	0	22	—
16T	50	480	45	45	6	12	12	M20	108	95,3	50,8	63,5	31,8	31,8	46	20,6	0	26	6
24T	75	480	63	63	—	12	12	M30	—	123,8	60,3	85,7	47,6	47,6	69,9	20,6	20,6	35	—
04E	12	1035	12	12	—	—	—	M12	—	42,1	—	31,75	16,7	16,7	23,8	—	—	18	—
08E	25	1240	25	25	6	10	10	M20	63,5	57,2	34,9	38,1	19,1	19,1	33,3	12,7	12,7	26	6
12E	40	1000	35	35	—	12	10	M24	—	79,4	44,5	50,8	34,9	34,9	41,3	20,6	0	22	—
16E	50	1380	45	40	—	—	—	M38	—	130,2	—	92,1	54	54	76,2	—	—	50	—

MOUNTING PATTERN
CHECK VALVES
HOUSE STANDARD CARTRIDGE MOUNTING
700 BAR
FOR VCC - **B.

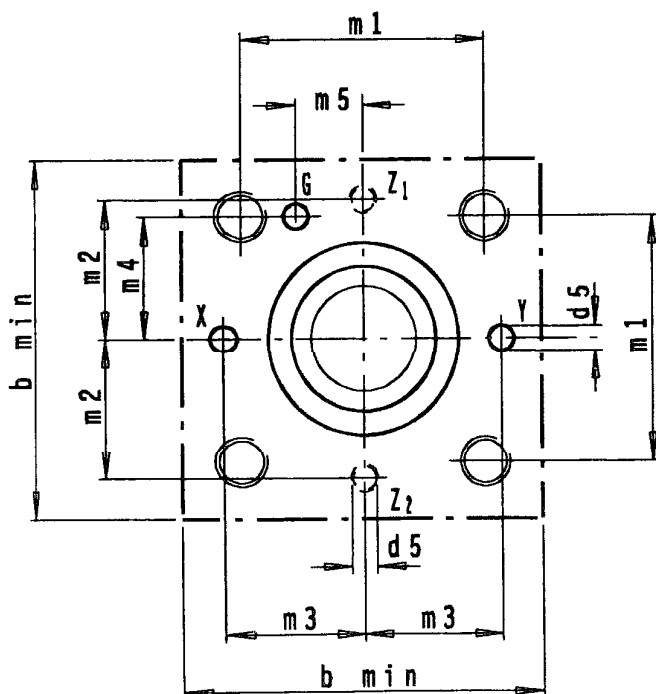
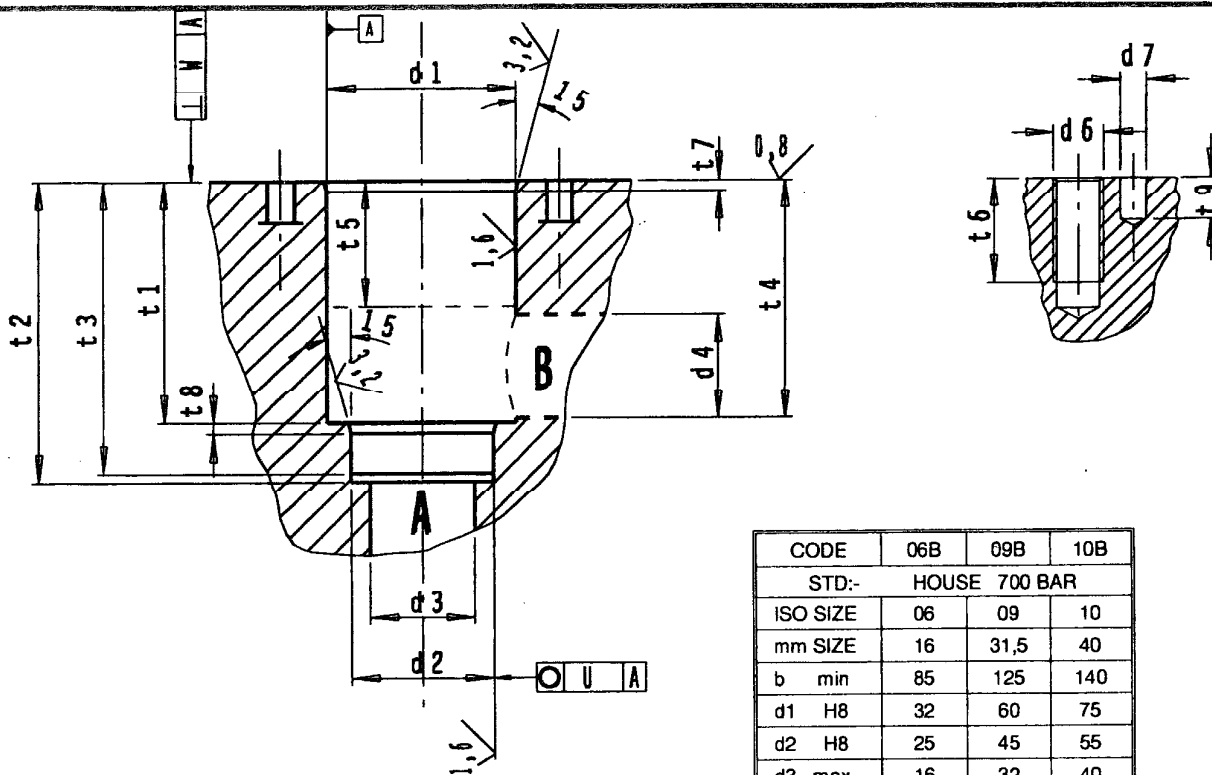

CODE	06B	09B	10B
STD:-	HOUSE 700 BAR		
ISO SIZE	06	09	10
mm SIZE	16	31,5	40
b min	85	125	140
d1 H8	32	60	75
d2 H8	25	45	55
d3 max	16	32	40
d4	16	31,5	40
d5 max	6	10	10
d6	M12	M20	M24
d7 H13	6	6	8
m1 ±0,2	58	85	100
m2 ±0,2	33	50	58
m3 ±0,2	33	50	58
m4 ±0,2	29	42,5	50
m5 ±0,2	16	23	30
t1 +0,1	43	70	87
t2 +0,1	56	85	105
t3	54	83	102
t4 max	42,5	68,5	84,5
t5	20	30	30
t6 max	30	46	46
t7	2	2,5	3
t8	2	2,5	3
t9 min	8	8	8
U	0,03	0,03	0,05
W	0,05	0,1	0,1

MOUNTING PATTERN
CHECK VALVES
HOUSE STANDARD CARTRIDGE MOUNTING
1400 BAR
FOR VCC - **J OR JB.

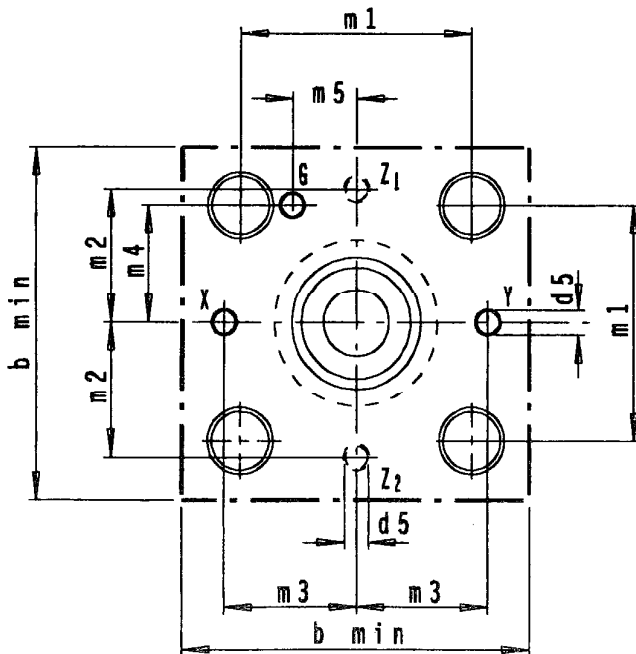
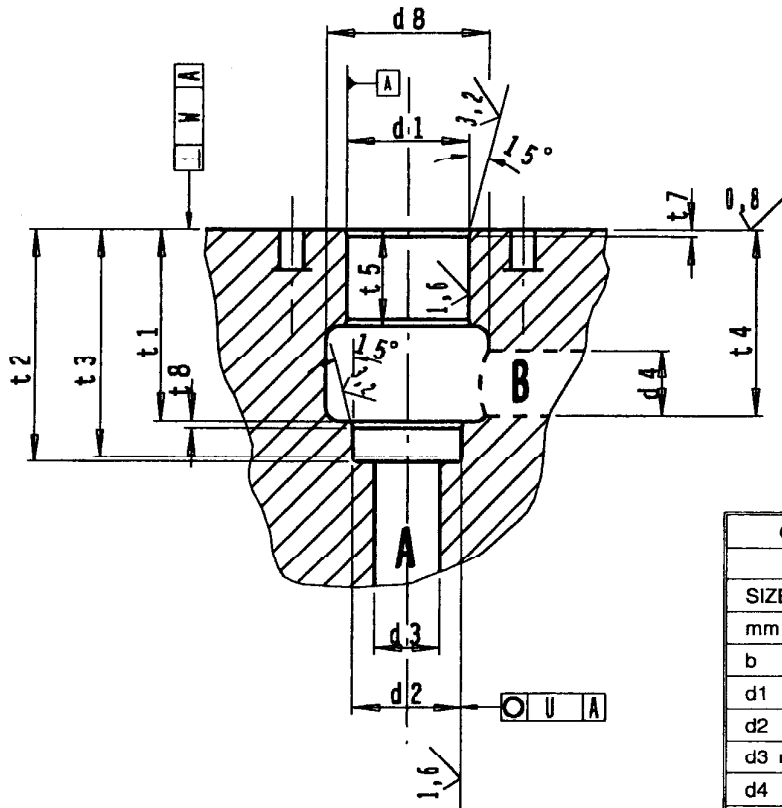

CODE	08J	08JB
STD:- HOUSE 1400 BAR		
SIZE	08	08
mm SIZE	24	24
b min	127	127
d1 H8	45	45
d2 H8	40	40
d3 max	24	24
d4	24	24
d5 max	10	10
d6	M24	M20
d7 H13	6	6
d8	60	60
m1 ±0,2	85	85
m2 ±0,2	50	50
m3 ±0,2	50	50
m4 ±0,2	42,5	42,5
m5 ±0,2	17	17
t1 +0,1	70	70
t2 +0,1	85	85
t3	83	83
t4 max	68	68
t5	32,5	32,5
t6 max	30	30
t7	2,5	2,5
t8	2,5	2,5
t9 min	10	10
U	0,02	0,02
W	0,1	0,1

MOUNTING PATTERN
CHECK VALVES
MANIFOLD CONVERSION BLOCKS
500 BAR.

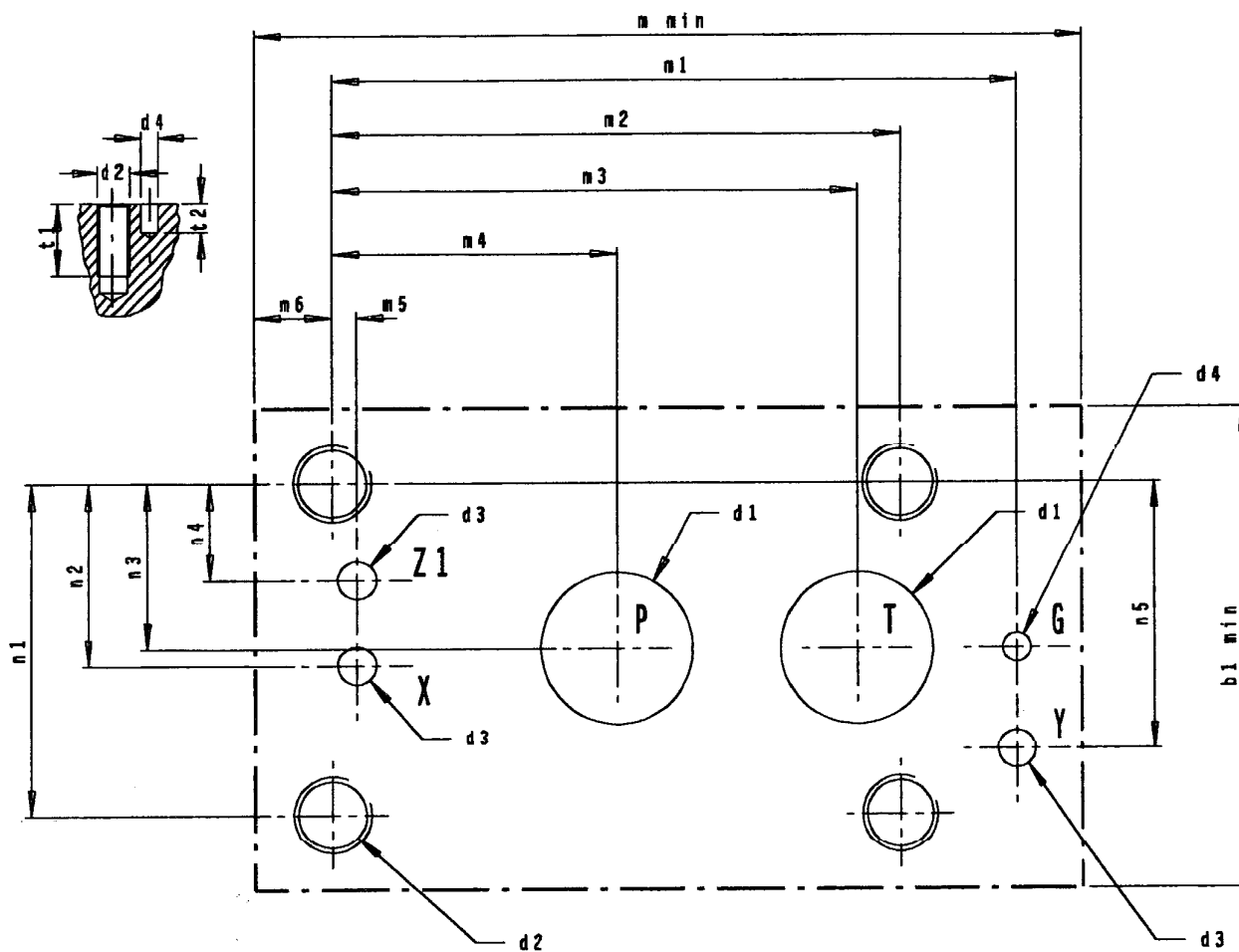

CODE / SIZE			CONVERSION BLOCKS																		
O / T	ISO	mm	b1 min	d1 max.	d2	d3	d4	m min	m1 ±0,1	m2 ±0,2	m3 ±0,1	m4 ±0,2	m5 ±0,2	m6 ±0,2	n1 ±0,1	n2 ±0,2	n3 ±0,2	n4 ±0,2	n5 ±0,2	t1	t2 min
06	06	16	65	16	M8	5	6	115	93	78	69	39	2	11	46	26	23	11	36,5	12	8
09	09	31,5	101,6	32	M16	8	6	170	140	118	109	59	5	16	70	38,5	35	20,5	56,5	24	8
10	10	40	127	40	M20	10	6	228	188	166	146	83	8	18	85	49	42,5	26	75	30	8

MOUNTING PATTERN
CHECK VALVES (PREFILL TYPE)
INSERTS - HOUSING DIMENSIONS
700 BAR.

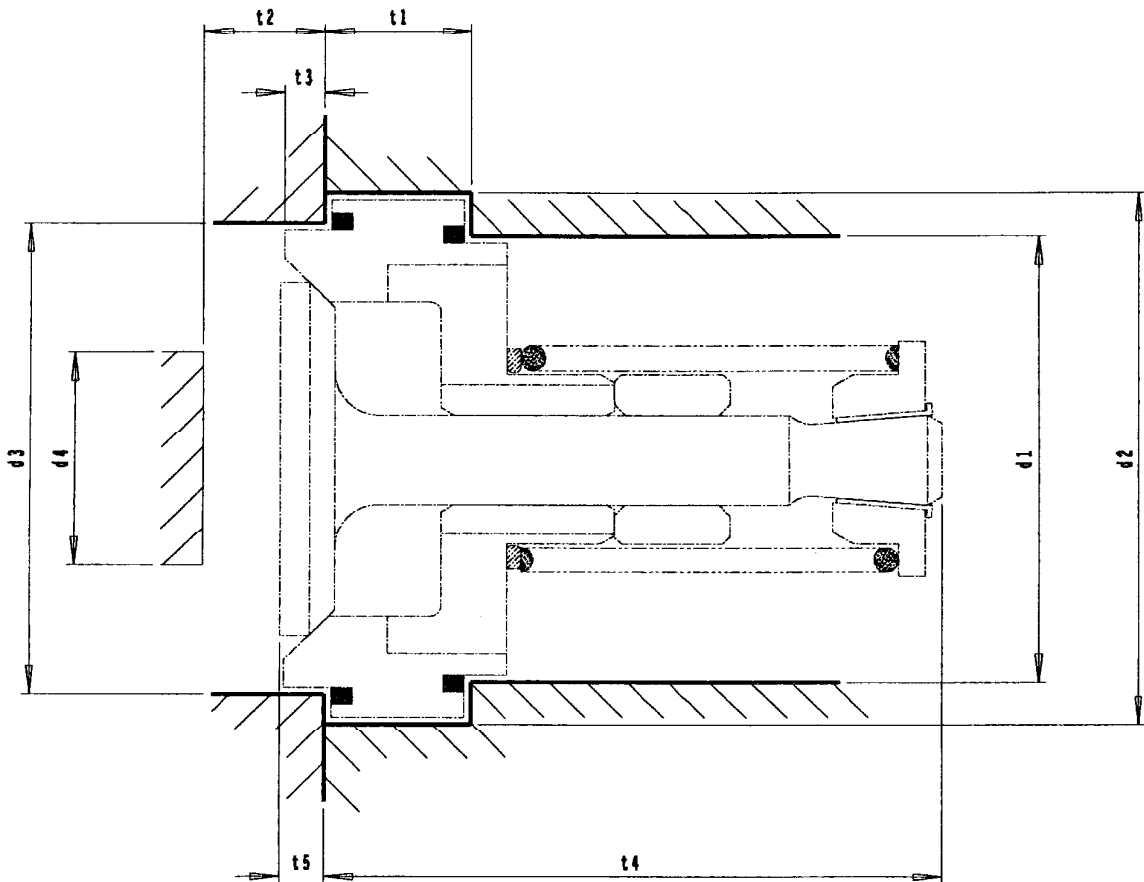

CODE / SIZE		W. P (BAR) max	STD:-				HOUSE CK***				
O / T	mm		d1	d2 +0,05	d3 +0,05	d4 Max	t1 ±0,05	t2	t3	t4 ±1,0	t5
40	40	700	48,4	57,14	50,1	30	12,5	10,8	1,6	57,3	2,8
50	50	700	61	73,01	64,6	41	15,8	14,1	1,5	69,7	4,6
65	65	500	72	85,73	78,7	47	18,98	19,7	1,5	105	5,7
90	90	500	127	160	128,6	92	35	49	22	138	24

CKMOUNT 14/12/93

The area of the annulus space $d3 - d4$ must be maintained and is given with $d4$ as a maximum dimension and therefore does not allow for any support bars which may be required. $d4$ will need to be made smaller to account for any area loss due to the support bars.

Oilgear Towler

VC★

CHECK VALVES.

The Oilgear Company

2300 South 51st Street
Milwaukee, WI USA 53219
Call toll free 1-800-558-6636
In WI call (414) 327-1700
Fax (414) 327-0532
Telex 2-69411