

# Measurement Solutions Product Guide

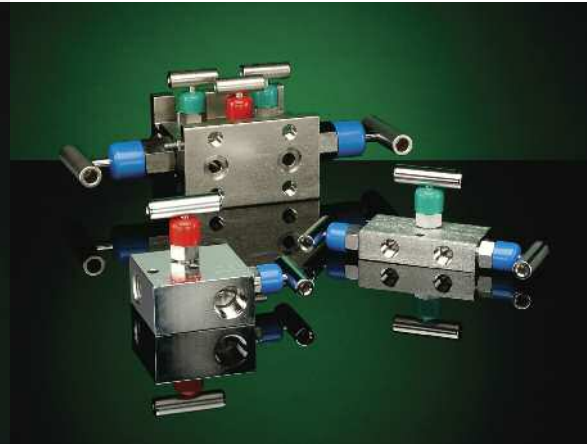

Pressure  
Level  
Temperature  
Force

Manifold Valves  
Needle Valves



**E**stablished in 1967, NOSHOK was one of the first companies to offer liquid filled pressure gauges. More importantly, NOSHOK was the first company to offer an extended three year warranty on pressure gauges. That standard of quality has endured for over 40 years. This commitment to product performance and service, and our sincere desire to be the best, is a continuing successful policy applied today to our pressure, level, temperature, force, and valve measurement solutions.

NOSHOK also has built the capacity to provide you with the assistance to put together that special requirement which is so often hard to find. If it is not in this catalog, chances are we can still put it together.

NOSHOK proudly backs its commitment to excellence and while you are viewing our catalog, I believe this commitment will become more apparent.

Thank you for choosing NOSHOK Products.



James B. Cole  
Chief Executive Officer



**N O S H O K   C o r p o r a t e   H e a d q u a r t e r s**

***Your Single Source Instrumentation Company***

NOSHOK is a member and actively supports:



**NOSHOK is an ISO 9001:2008 registered company**

# T A B L E O F C O N T E N T S

The  
Instrumentation  
Company



## PRESSURE AND LEVEL MEASUREMENT SOLUTIONS

<b>Pressure Gauges</b>	
100, 200, 300, 400/500, 600/700, 800, 900 and 1000 Series	4-5
<b>Pressure Gauge Accessories &amp; Options</b>	6-7
<b>Differential Pressure Gauges</b>	
1000, 1100, 1200 and 1300 Series	8
<b>Digital Indicators</b>	
1800, 1900C, 1950 and 2000/2100 Series	9
<b>Pressure and Level Transmitters &amp; Transducers</b>	
100, 200, 300, 612, 615/616, 630, 640, 650, 660, and 755/756 Series	10-13
<b>Hazardous Location Transmitters</b>	
619/620, 621/622, 623/624, 625/626 and 627 Series	11-12
<b>Pressure Switches &amp; Switch/Transmitters</b>	
100, 200, 300, 400, 500, 600 and 800/810 Series	13-14
<b>Sanitary Pressure Instruments</b>	
10, 11, 20 and 21 Series	15
<b>Diaphragm Seals</b>	
Type 10, 10L, 10H, 12, 20, 25, 25H, 29, 30, 30H and 30L	16-17

## TEMPERATURE MEASUREMENT SOLUTIONS

<b>Bimetal Thermometers</b>	
100 and 300 Series	18
<b>Temperature Transmitters &amp; Switch/Transmitters</b>	
800 and 850 Series	18
<b>Vapor Actuated Remote Thermometers and Thermowells</b>	19

## FORCE MEASUREMENT SOLUTIONS

<b>Hydraulic Load Cells</b>	
1000, 2000, 3000, 4000 and 5000 Series	19-20
<b>Custom Force Sensors</b>	21
<b>Chain Hoist Test Kit &amp; Weld Force Test Kit</b>	22
<b>Load Pins, Tension and Compression Force Transducers, S-Type</b>	22-23

## VALVE PRODUCT SOLUTIONS

<b>Needle Valves</b>	
100/150, 200/300, 400/500, 600/700, 800/850 and 2070/2170 Series	24-25
<b>Manifolds Valves</b>	
<b>2-Valve Static Pressure &amp; Liquid Level Manifolds</b> 2000/2100, 200002/210002, 200402/210402, 2602/2702, 2603/2703, 2604/2704 and 2020/2120 Series	26-27
<b>3-Valve Differential Pressure Manifolds</b>	
3010/3110, 3510 and 3610/3710 Series	27-28
<b>5-Valve Natural Gas Manifolds</b> 5030/5130, and 5530 Series	28-29
<b>Valve Accessories</b>	29

Please refer to the individual product catalogs for detailed warranty information.

In keeping with and for purpose of product and/or manufacturing process improvements, NOSHOK, INC. reserves the right to make design changes without prior notice.

# PRESSURE GAUGES

## SPECIFICATIONS

**SIZES:** 1-1/2, 2, 2-1/2 and 4 inch  
**CONNECTION LOCATION:** Bottom, back, left and right side connections  
**CONNECTION SIZE:** 1/8 inch NPT and 1/4 inch NPT dependent upon model and size. Other connections available upon special request  
**CASE:** ABS is standard. Steel, chrome and stainless steel are available as options  
**LENS:** Plexiglass is standard. Glass is available as an option on certain models.  
**BOURDON TUBE:** Brass and copper alloys  
**MOVEMENT:** All brass or brass and Delrin®  
**ACCURACY:** ± 1% Full Scale to ± 2.5% Full Scale dependent on model  
**AVAILABLE RANGES:** Vacuum and compound through 15,000 psi.  
**OPTIONS AND ACCESSORIES:** Panel mount options, cover rings, orifices, rubber case protectors, recalibrators, special connections and more

**OPERATING LIMITATIONS WORKING PRESSURE:**  
**DYNAMIC:** 60% of dial range  
**STATIC:** 90% of dial range  
**TEMPERATURE:** 0 °F to 140 °F (-18 °C to 60 °C)

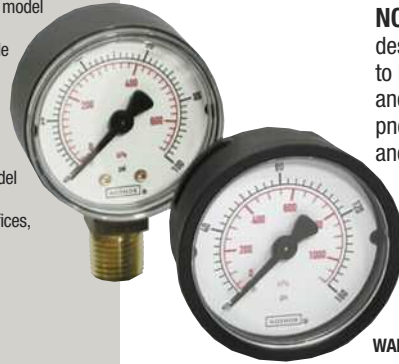

## 100 SERIES

**NOSHOK STANDARD GAUGES** are high quality dry gauges designed to provide reliable service on applications not corrosive to brass. They are used in almost every area of manufacturing and are especially suited for applications in hydraulics, pneumatics, process, petrochemical, medical, pharmaceutical and most industrial and commercial applications.

**WARRANTY:** One Year†

## SPECIFICATIONS

**SIZES:** 2, 2-1/2 and 4 inch  
**CONNECTION LOCATION:** Bottom, back, left and right side connections  
**CONNECTION SIZE:** 1/4 inch NPT bottom and back connection.  
**CASE:** ABS, Black painted steel or 304 stainless steel dependent on model and size  
**LENS:** Clearfront plexiglass on the 2-1/2 inch size, instrument glass on the 4 inch size.  
**DIAPHRAGM CAPSULE:** Copper alloy  
**MOVEMENT:** Brass, bearing parts highly polished nickel silver with zero point adjustment  
**ACCURACY:** 2-1/2 inch, ± 1.5% Full Scale; 4 inch, ± 1% Full Scale  
**AVAILABLE RANGES:** 0-100 inch H<sub>2</sub>O Vacuum through 0-10 psi  
**OPTIONS AND ACCESSORIES:** Panel mount options, orifices, over-pressure protection, custom ranges and dials, special connections and more

**OPERATING LIMITATIONS WORKING PRESSURE:**  
**DYNAMIC:** 60% of dial range  
**STATIC:** 90% of dial range  
**TEMPERATURE:** 0 °F to 140 °F (-18 °C to 60 °C)



## 200 SERIES

**NOSHOK LOW PRESSURE DIAPHRAGM GAUGES** are designed for extremely low pressure and vacuum measurement. The ultra sensitive copper alloy diaphragm capsules are rated for pressure as low as 0-10 inH<sub>2</sub>O and as high as 0-10 psi. Applications include HVAC service, filtration, gas distribution, waste water treatment, medical and everywhere low pressure and vacuum measurement is required.

**WARRANTY:** One Year†

## SPECIFICATIONS

**SIZES:** 2-1/2 inch and 4 inch  
**CONNECTION:** 1/4 inch NPT bottom and back. 7/16 inch-20 SAE-4 and 1/2 inch NPT available  
**CASE:** One piece die cast brass  
**LENS:** Molded plexiglass with o-ring seal  
**BOURDON TUBE:** 2-1/2 inch size: phosphor bronze through 6,000 psi and 316 stainless steel on higher ranges 4 inch size: phosphor bronze through 800 psi and 316 stainless steel on higher ranges  
**MOVEMENT:** Brass and nickel silver  
**ACCURACY:** 2-1/2 inch, ± 1.5% Full Scale; 4 inch, ± 1% Full Scale  
**AVAILABLE RANGES:** Vacuum and compound through 15,000 psi.  
**OPTIONS AND ACCESSORIES:** Panel mount options, cover rings, max indicating pointers, orifices, rubber case protectors, special connections, metric dials and more

**OPERATING LIMITATIONS WORKING PRESSURE:**  
**DYNAMIC:** 60% of dial range  
**STATIC:** 90% of dial range  
**TEMPERATURE:** 0 °F to 140 °F (-18 °C to 60 °C)



## 300 SERIES

**NOSHOK BRASS CASE GAUGES** are the highest quality, most reliable liquid filled gauges available. Their one piece die cast brass case and heavy duty bourdon tube and movement enables them to stand up to shock and vibration encountered on the most demanding applications.

**WARRANTY:** Three Years†

## SPECIFICATIONS

**SIZES:** 1-1/2, 2, 2-1/2, 4 and 6 inch  
**CONNECTION:** 1/8 inch NPT on 1-1/2 inch sizes, 1/4 inch NPT on 2, 2-1/2 and 4 inch sizes, 1/2 inch NPT on 4 inch and 6 inch sizes. Available in bottom and back configurations  
**CASE:** 304 stainless steel  
**LENS:** Plexiglass on 1-1/2 inch and 2 inch, Trogamide on 2-1/2 inch, Instrument glass on 4 inch and Safety glass on 6 inch sizes  
**BOURDON TUBE:** 316 stainless steel  
**MOVEMENT:** 300 Series stainless steel  
**ACCURACY:** ± 2.5% Full Scale on 1-1/2 inch and 2 inch sizes; ± 1.5% Full Scale on 2-1/2 inch size; ± 1% Full Scale on 4 inch and 6 inch sizes  
**AVAILABLE RANGES:** Vacuum and compound through 100,000 psi. dependent on model and size  
**OPTIONS AND ACCESSORIES:** Panel mount options, orifices, adjustable pointers, max indicating pointers, metric and special dials, special connections and more

**OPERATING LIMITATIONS WORKING PRESSURE:**  
**DYNAMIC:** 60% of dial range  
**STATIC:** 90% of dial range  
**TEMPERATURE:** 400 Series: -40 °F to 260 °F (-40 °C to 127 °C)  
500 Series: 0 °F to 160 °F (-18 °C to 71 °C)



## 400/500 SERIES

**NOSHOK DRY AND LIQUID FILLED ALL STAINLESS STEEL GAUGES** are the ultimate corrosion resistant, heavy duty, vacuum and pressure gauges. They are used in corrosive service world-wide where ruggedness and reliability are critical. Typical applications include chemical and petroleum refineries, pharmaceutical, offshore drilling and production, paper mills and more.

**WARRANTY:** 400 Series: One Year†  
500 Series: Three Years†

**Extreme High Pressure Ranges Available**

† For further warranty information please consult your specific product catalogs.

## SPECIFICATIONS

**SIZES:** 4-1/2 inch  
**CONNECTION:** Bottom connection, 1/4 inch or 1/2 inch NPT  
**CASE:** Turret style, black phenolic, solid front, safety case with blowout back  
**BAYONET RING:** Threaded black phenolic  
**LENS:** Acrylic  
**BOURDON TUBE:** 600 Series: copper alloy through 600 psi and 316 stainless steel above 600 psi  
**700 Series:** 316 stainless steel  
**MOVEMENT:** 600 Series: brass and nickel silver; 700 Series: stainless steel  
**ACCURACY:** ± 0.5% Full Scale ± 1.5% on inH<sub>2</sub>O ranges  
**RANGES:** Vacuum and compound through 60,000 psi.  
**OPTIONS AND ACCESSORIES:** Dampened movement, receiver gauges and Reid Vapor Test configurations, panel mounting options, liquid filling, optional lenses, orifices, metric and special dials, special connections and more

### OPERATING LIMITATIONS WORKING PRESSURE:

**DYNAMIC:** 60% of dial range  
**STATIC:** 90% of dial range  
**TEMPERATURE:** Series 640 and 740 (dry): -40°F to 160°F (-40°C to 71°C)  
 Series 660 and 760 (liquid filled): 0 to 140°F (-18°C to 60°C)



## 600/700 SERIES

**NOSHOK 4-1/2 INCH COPPER ALLOY AND 316 STAINLESS STEEL PHENOLIC CASE PROCESS GAUGES** are specifically designed for demanding service in chemical, petroleum and industrial processing industries. They are widely used throughout the world on applications where accuracy, readability, safety and reliability are important.

**WARRANTY:** 600/740 Series: One Year†  
 660/760 Series: Three Years†

**Extreme High Pressure and Extreme Low Pressure Diaphragm Ranges Available**

## SPECIFICATIONS

**SIZES:** 6 inch  
**CONNECTION:** 1/4 inch NPT bottom connection  
**CASE:** 304 stainless steel  
**BEZEL:** 304 stainless steel  
**LENS:** Instrument glass  
**BOURDON TUBE:** beryllium copper  
**MOVEMENT:** jeweled, brass and nickel silver  
**ACCURACY:** ± 0.25% Full Scale  
**AVAILABLE RANGES:** Vacuum and compound through 20,000 psi  
**OPTIONS AND ACCESSORIES:** Panel mount options, orifices, special connections, carrying cases and more

### OPERATING LIMITATIONS WORKING PRESSURE:

**STATIC:** 100% of dial range (Not recommended for dynamic applications)  
**TEMPERATURE:** 0° F to 140° F (-18° C to 60° C)  
**Reference calibration temp:** 70° F (21° C)



## 800 SERIES

**NOSHOK PRECISION TEST GAUGES** are the highest quality test gauges with accuracy levels meeting ANSI B40.1 Grade 3A. They are used in laboratories, calibration stands, aerospace and wherever accuracy and sensitivity are critical parameters in measurement. The NOSHOK adjustable knife-edge pointer in conjunction with the mirror dial band eliminate parallax\* error. (\*The difference in apparent direction of an object as seen from two different points not on a straight line with the object.)

**WARRANTY:** One Year†

## SPECIFICATIONS

**SIZES:** 1-1/2, 2-1/2 and 4 inch  
**CONNECTION:** 1/8 inch NPT back connection on 1-1/2 inch size, 1/4 inch NPT bottom and back on 2-1/2 inch and 4 inch sizes  
**CASE:** ABS or 304 stainless steel dependent on model  
**LENS:** Plexiglass on 1-1/2 and 2-1/2 inch instrument glass on 4 inch  
**BOURDON TUBE:** brass and copper alloy  
**MOVEMENT:** brass and Delrin, and all brass  
**ACCURACY:** ± 1.5% Full Scale on ± 2.5% Full Scale on 1-1/2 inch, 2-1/2 inch sizes ± 1% Full Scale on 4 inch sizes  
**AVAILABLE RANGES:** Vacuum and compound through 15,000 psi.  
**OPTIONS AND ACCESSORIES:** Panel mount options, orifices, rubber case protectors, special connections, special dials and more

### OPERATING LIMITATIONS WORKING PRESSURE:

**DYNAMIC:** 60% of dial range  
**STATIC:** 90% of dial range  
**TEMPERATURE:** 0° F to 140° F (-18° C to 60° C)



## 900 SERIES

**NOSHOK LIQUID FILLED GAUGES** are high quality gauges that incorporate unique design features aimed at extended service life and reliability. They are used world-wide where pulsation, vibration and shock are present and the media is not corrosive to brass.

**WARRANTY:** Three Years†

## SPECIFICATIONS

**HOUSING MATERIAL:** 304 stainless steel  
**DISPLAY:** 4 digit, up to 9999  
**WETTED MATERIALS:** ≤750 psig stainless steel, aluminum, NBR, ceramic measuring element  
 ≥1000 psig stainless steel, thin-film measuring element  
**ACCURACY:** ±0.25% Full Scale; ±0.5 Terminal point  
**UPDATE RATE:** 5 times/sec  
**RANGES:** Standard gauge ranges from 30 psig through 10000 psig; compound ranges from 30/30 psig through 30/600 psig, compound ranges from 30/30 psig through 30/600 psig  
**POWER SUPPLY:** 2 x 1.5V AA battery 4000 hrs (AA 2000 mAh)  
**ON/OFF SWITCH:** Manual; auto shut-off optional

CE Compliant to EMC norm EN61326:1997/A1:1998 RFI, EMI, ESD protection; NEMA 4X to EN60529/IEC529



## 1000 SERIES



**NOSHOK HIGH PERFORMANCE DIGITAL PRESSURE GAUGES** are designed to exceed the industry's most demanding application requirements. Using the latest in reliable ceramic thick film strain gage technology combined with low power electronics, these gauges are accurate, stable and extremely reliable. The 1000 Series gauges are ideally suited for local indication.

**WARRANTY:** Three Years†

† For further warranty information please consult your specific product catalogs.

# PRESSURE GAUGE ACCESSORIES & OPTIONS

**PIGTAIL STEAM SYPHONS**



**PIGTAIL STEAM SYPHONS** protect the instrument from the damaging effects of high temperature steam and should be used in all steam applications. They are available in 1/4 inch and 1/2 inch NPT sizes in welded steel, welded 316 stainless steel or seamless 316 stainless steel with ratings to 3800 psi @ 850 °F.

**PISTON TYPE SNUBBERS**



**PISTON TYPE SNUBBERS** resist clogging and are self cleaning. Five different sized pistons are included with each snubber to insure the correct amount of snubbing for virtually every application. They are available in brass and 316 stainless steel in either 1/4 inch NPT, 1/2 inch NPT or 7/16-20 SAE-4

**WARRANTY:** One Year†

**SWIVEL ADAPTER**

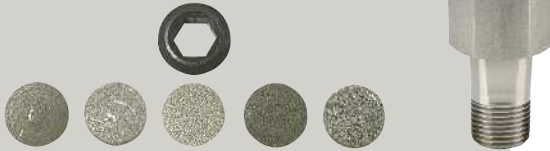

**SINTERED SNUBBERS** are a cost-effective solution to protect expensive instrumentation. These snubbers increase gauge readability by smoothing out pressure surges, pulsations and spikes, and they eliminate instrument failure due to pressure shock. Five basic discs are available to accommodate 90% of applications. Snubbing action is achieved by utilizing a corrosion-resistant 316 stainless steel sintered element; exotic materials or intermediate disc grades are available on a per order basis. NOSHOK Sintered Snubbers provide long service life with no moving parts to wear out.

**SINTERED SNUBBER REPLACEMENT DISCS**

**SWIVEL ADAPTERS** are used with gauges and gauge valves to adjust the line of sight. The swivel adapter rotates 360° to allow the connected instrument to be positioned in the desired direction and has temperature ratings of 15,000 psi @ 200 °F and 3,000 psi @ 1000 °F. The pressure connection is achieved with a tapered cone style compression fitting simply by tightening the swivel hex nut. They feature all 316 stainless steel construction, and are standard with 1/2 inch NPT male process – 1/2 inch NPT female instrument connections. Also available with 1/4 inch NPT connections.

**CHROME FRONT FLANGE**



## PANEL MOUNTING

Many panel mounting options are available and can be installed in the field. Options include polished brass front flanges (BFF), black painted steel front flanges (BLFF), chrome front flanges (CFF), polished stainless steel front flanges (SSFF), chrome triangular bezel front flanges with U-clamp (CB-U), black painted steel triangular bezels with U-clamp (BB-U-Clamp), polished stainless steel narrow bezel front flanges (SSB-U), and panel mount clamps (PMC). Chrome plated steel adapter rings (AR) are available in conjunction with several of these flanges to adapt to oversized panel cut outs. A selection of flange rings are also offered: polished stainless steel flange rings (SSFR), chrome plated steel flange rings (CFR), and black or chrome panel mount rings (BPMR & CPMR). Brass rear flanges (BRF) and black rear flanges (BLRF) for front of panel mounting are also available on some models. Rear Flanges are a factory installed option.

**PANEL MOUNT CLAMP**

**POLISHED BRASS FRONT FLANGE**



## CASES AND COVER RINGS

Black painted steel (BCR), chrome plated steel (CCR) and 304 stainless steel (SSCR) cases and cover rings are available on many models as production options.

**CHROME TRIANGULAR BEZEL WITH U-CLAMP**



**REAR FLANGE**



**CASES AND COVER RINGS**



## LENSES

Instrument glass lenses, laminated safety glass lenses, plexiglass lenses, and homalite lenses (resistant to many industrial solvents) are available on many models. NOTE: A steel or stainless steel case and cover ring is required when other than plexiglass lenses are utilized. Some models are also available with a solid front, safety case configuration as a production option.

**MAXIMUM INDICATING POINTERS**



**MAXIMUM INDICATING POINTERS (MIP)** are an invaluable tool for identifying pressure spikes in a system. They are very helpful during system start up and trouble shooting. MIPs add an additional  $\pm 1\%$  error to the gauge because of the increased load on the bourdon tube. On ranges of 60 psi and lower, MIPs may double the allowed error of the gauge.

**SET POINTERS (SP)** are used to identify an operating minimum or maximum pressure or vacuum value. Set pointers are available on most 100 Series gauges.



**SET POINTERS**

### RUBBER CASE PROTECTORS (RCP)

Rubber case protectors (RCP) are ideal for gauges that are subjected to direct physical shock. 2-1/2 inch covers are blue and 4 inch covers are black.

### ORIFICES

Press-fit brass orifices or threaded 316 stainless steel orifices are available on all NOSHOK pressure gauges. They are standard with .012 inch I.D or .032 inch I.D, depending on the model. Orifices are used in a gauge to restrict the flow of rapidly increasing and decreasing pressures, thereby lessening the immediate effect of pulsations and pressure spikes. Orifices are recommended for all dynamic applications.

### RECALIBRATORS

The option of an adjustment screw accessible through the dial facilitates re-setting the zero point without disassembling the gauge.

### OVER PRESSURE PROTECTION

Over pressure protection of up to 200% of the dial range is available on some models as a production option.

### AMMONIA REFRIGERATION GAUGES

Ammonia refrigeration gauges with dials reading in both pressure and temperature are available in 400/500 Series 2-1/2 and 4 inch sizes.

**RUBBER CASE PROTECTORS**



### LIQUID FILLING OPTIONS

Many NOSHOK gauges are available with liquid filling options. Our standard fill is glycerine and water; however, optional fill liquids include Dow Corning 200 silicone and halocarbon.

### SPECIAL CONNECTIONS

Special connections are available on most NOSHOK gauges. Some examples include: metric threads, female threads, straight threads (flare or swivel type) and special O-ring connections. Please contact us with your requirements for prices, availability and minimum quantities.

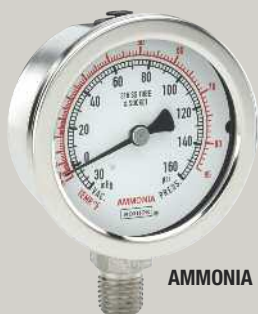

**AMMONIA REFRIGERATION GAUGES**

### REID VAPOR TEST GAUGES

A Reid Vapor test gauge configuration which includes a handle, special dial and special pressure part is available in 600/700 Series gauges with pressure ranges of 0-5 psi, 0-15 psi and 0-30 psi.

### RECEIVER GAUGES

3-15 psi receiver gauges are available in both 600 Series (Brass) and 700 Series (316 stainless steel) configurations.

### METRIC DIALS AND CUSTOMIZED SPECIAL DIALS

Dual scale Metric Dials in psi/bar, psi/kPa and psi/kg/cm<sup>2</sup> are available on many models. Certain other scales are available for specific sizes and ranges, such as single scale bar and kPa, refrigerant scales and altitude scales. Please consult the factory for availability. Special Dials such as non-standard metric scale, tons of ram, lbs. of force, etc. are available in small quantities (as few as one piece) on some models.

### CERTIFIED CALIBRATION

Certified calibration is available on all NOSHOK gauges. Certified calibration provides the user with a serial numbered gauge along with a calibration sheet against a primary pressure standard and is traceable to the National Institute of Standards and Technology.

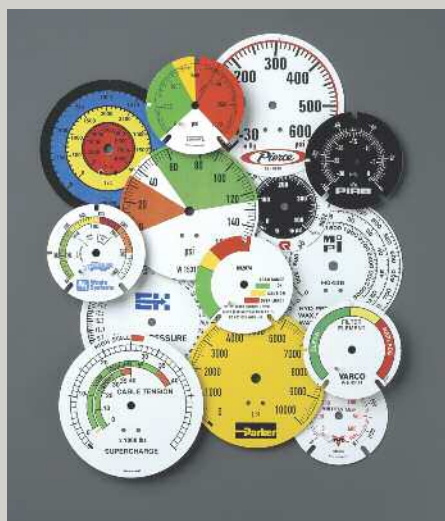

# DIFFERENTIAL PRESSURE GAUGES

## SPECIFICATIONS

**SIZES:** 2-1/2 inch and 4-1/2 inch

**CASE MATERIAL:** Fiberglass reinforced plastic – STD.

**LENS:** Acrylic – STD; Laminated safety glass – Opt.; Acrylic w/ MIP – Opt.; Acrylic with alarm contacts – Opt.

**SENSOR HOUSING MATERIAL:** Aluminum, black – STD; 316L stainless steel – Opt.

**PROCESS CONNECTION:** 1/4 inch F-F NPT, back connection – STD; Other 1/4 inch F-F NPT with back or side connections available

**ACCURACY:** ±2% Full Scale on rising pressure

**RANGES:** 0 psid to 5 psid through 0 psid to 100 psid

**OPTIONAL FILL FLUIDS:** Glycerine, Silicone or Halocarbon

### OPERATING LIMITATIONS:

**TEMPERATURE:** -40 °F to 200 °F (-40 °C to 93 °C)

**MAXIMUM WORKING STATIC**

**PRESSURE:** 6,000 psig



## 1000 SERIES

**NOSHOK PISTON TYPE DIFFERENTIAL GAUGES** are designed for measuring pressure drop across filters, strainers, separators and valves. The single piece construction of the ceramic magnet/piston is designed to reduce “blow by” and increase gauge accuracy. These gauges can be found in applications requiring high differential pressure from 0 to 5 psid to 0 to 100 psid with maximum working/static pressure to 6,000 psig.

**WARRANTY:** 1000 Series (dry): One Year†  
1000 Series (liquid filled): Three Years†

## SPECIFICATIONS

**SIZES:** 2-1/2 inch and 4-1/2 inch

**CASE MATERIAL:** Fiberglass reinforced plastic – STD.

**LENS:** Acrylic – STD; Laminated safety glass – Opt.; acrylic w/ MIP – Opt.

**SENSOR HOUSING MATERIAL:** Aluminum, black – STD; 316L stainless steel – Opt. Brass – Opt.

**PROCESS CONNECTION:** 1/4 inch F-F NPT, back connection – STD; Other 1/4 inch F-F NPT with top and bottom connections available

**ACCURACY:** ±2% Full Scale on for ranges 0 to 15 psid and above;

±5% Full Scale for ranges below 0 to 15 psid

**RANGES:** 0 inH<sub>2</sub>O to 50 inH<sub>2</sub>O through 0 psid to 100 psid

**OPTIONAL FILL FLUIDS:** Glycerine, Silicone or Halocarbon

### OPERATING LIMITATIONS:

**TEMPERATURE:** -40 °F to 200 °F

(-40 °C to 93 °C)

**MAXIMUM WORKING STATIC**

**PRESSURE:** 3,000 psig - stainless steel and aluminum,

and 1,500 psig - brass



## 1100 SERIES

**NOSHOK DIAPHRAGM TYPE DIFFERENTIAL GAUGES** are designed for applications where higher levels of solids are present in the measuring media. The magnetic piston and polymeric diaphragm are utilized to measure the low to high differential pressure. The isolation of the high and low inlets prevents fluid movement between the ports. They are used in measuring pressure drops across filters, strainers, separators, heat exchangers and more.

**WARRANTY:** 1100 Series (dry): One Year†  
1100 Series (liquid filled): Three Years†

## SPECIFICATIONS

**SIZES:** 4-1/2 inch and 6 inch

**CASE MATERIAL:** Aluminum, black – STD; 316L stainless steel – Optional

**LENS:** acrylic – STD; laminated safety glass

**SENSOR HOUSING MATERIAL:** 316L stainless steel – STD

**PROCESS CONNECTION:** 1/4 inch F-F NPT, back connection – STD; Other 1/4 inch F-F NPT with dual top and bottom connection available

**ACCURACY:** ±1% Full Scale on rising pressure

**RANGES:** 0 to 100 inH<sub>2</sub>O through 0 to 600 psid

**OPTIONAL FILL FLUIDS:** Glycerine, Silicone or Halocarbon

### OPERATING LIMITATIONS:

**TEMPERATURE:** -40 °F to 200 °F (-40 °C to 93 °C)

**MAXIMUM WORKING STATIC**

**PRESSURE:** 3,000 psig



## 1200 SERIES

**NOSHOK MEMBRANE TYPE HIGH STATIC DIFFERENTIAL PRESSURE GAUGES** are designed for applications requiring high static pressure and high differential pressure measurement. Utilizing opposing Monel membranes, halocarbon fill and a bi-directional overpressure valve these gauges are suited for applications in hydraulic and pneumatic systems, filters, flow indicators and caustic liquid or gaseous media. A liquid filled case is available to dampen the effects of pulsation, vibration and shock.

**WARRANTY:** 1200 Series (dry): One Year†  
1200 Series (liquid filled): Three Years†

## SPECIFICATIONS

**SIZES:** 4-1/2 inch and 6 inch

**CASE MATERIAL:** Aluminum, black – STD; 316L stainless steel – Optional

**LENS:** Acrylic – STD; Laminated safety glass

**SENSOR HOUSING MATERIAL:** 316L stainless steel – STD

**PROCESS CONNECTION:** 1/4 inch F-F NPT, dual top and bottom connection – STD; Other 1/4 inch F-F NPT with back connection available

**ACCURACY:** ±1% Full Scale on rising pressure

**RANGES:** 0 to 100 inH<sub>2</sub>O through 0 to 400 psid

**OPTIONAL FILL FLUIDS:** Glycerine, Silicone or Halocarbon

### OPERATING LIMITATIONS:

**TEMPERATURE:** -40 °F to 200 °F (-40 °C to 93 °C)

**MAXIMUM WORKING STATIC**

**PRESSURE:** 600 psig



## 1300 SERIES

**NOSHOK MEMBRANE TYPE NOMINAL STATIC DIFFERENTIAL PRESSURE GAUGES** are designed for integral process applications requiring nominal static and low differential pressure measurement. The black anodized aluminum case and 316L stainless steel sensor housing combine to form a durable case construction with NEMA 4X rating. These gauges are suited for application in caustic liquid or gaseous media and/or low temperature gases, water treatment systems, filters, strainers, pumps and more.

**WARRANTY:** 1300 Series (dry): One Year†  
1300 Series (liquid filled): Three Years†





## SPECIFICATIONS

**DISPLAY:** 0.4 inch LCD  
**DIGITS:** 4, from -1999 to 9999  
**ACCURACY:**  $\pm 0.2\%$  Full Scale,  $\pm 1$  digit  
**UPDATE RATE:** 5 times/sec  
**RANGE:** The 4 mA to 20 mA signal from the transmitter can be assigned any display value within the display range.  
**POWER:** Loop-powered; No additional power supply required; Maximum current rating is 40 mA and voltage drop of 3 Vdc

CE Compliant to EMC norm EN61326:1997/A1:1998 RFI, EMI, ESD protection; NEMA 4X to EN60529/IEC529



## 1800 SERIES

### NOSHOK ATTACHABLE LOOP POWERED DIGITAL INDICATOR

utilizes a transmitters' 4mA to 20mA output signal and the Hirschmann connector for local pressure indication. It is simply inserted between the transmitter body and the connector without the need for additional wiring or power source. The indicator is programmable to display a range of -1999 to 9999 and may be tilted for better viewing. There is a user selectable digital filtering to improve readability in rapidly varying pressure pulsations. Available with optional relay that is programmable through the front of the meter.

**WARRANTY:** One Year†

## SPECIFICATIONS

**DISPLAY:** 3-1/2 inch digit LCD from -1999 to 1999  
**INPUT SIGNAL:** Current: 4 mA to 20 mA  
**SPAN RANGE:** 0 to 1999  
**OFFSET RANGE:** -1999 to 1999  
**LINEARITY:**  $\pm 0.1\%$  to 1 digit  
**READING RATE:** 2.5 readings per second, nominal  
**RESPONSE TIME:** 1.5 seconds to settle for a step change

CE Compliant to EMC norm EN61326:1997/A1:1998 RFI, EMI, ESD protection; NEMA 4X to EN60529/IEC529



## 1900C SERIES

### NOSHOK COMPACT LOOP POWERED DIGITAL INDICATORS

provide digital display of any desired unit of pressure, temperature, level, and force or flow measurement. Their 3-1/2 inch digit display has a span range of 0 to 1999 and is available in a positive image reflective LCD or in an optional red or yellow/green back-lit version.

**WARRANTY:** One Year†

## SPECIFICATIONS

**ENCLOSURE:** Black painted steel or off-white fiberglass optional  
**DISPLAY:** 5 digit, 0.48 inch high (-9999 to 99999) LCD  
**INPUT SIGNAL:** Current: 4 mA to 20 mA  
 Voltage: 0 Vdc to 10 Vdc; Resistance: 100 ohm pt  
**POWER REQUIREMENT:** 9 Vdc to 28 Vdc (optional power supply available for 85 Vac to 250 Vac excitation)  
**ELECTRICAL CONNECTIONS:** Terminal block in rear, recommended wire: 30 to 14 AWG copper  
**OPTIONAL POWER SUPPLIES:** 115 Vac to 12 Vdc (400 mA); 115 Vac to 24 Vdc (200 mA); or 115 Vac to 12 Vdc (80 mA)

CE Compliant to EMC norm EN61326:1997/A1:1998 RFI, EMI, ESD protection; NEMA 4X to EN60529/IEC529



## 1950 SERIES

### NOSHOK COMPACT SMART SYSTEM DIGITAL INDICATOR

offers all the features of a full size panel meter compressed into a small design for ease of installation in almost any application. The 5 digit display has a span range of -9999 to 99999 and is available in reflective LCD and selectable red or green backlit versions. The display can accept a variety of process signals for applications in pressure, flow, level, force and temperature. All programming can be done easily through the front of the meter. The display is fully expandable to accommodate applications requiring relays, dual sinking outputs, and serial communications by RS232 or RS485. NOSHOK calibrates all of its indicators to your transducer requirements at no additional cost. Simply tell us how you want it set up, then plug it in and go!

**WARRANTY:** One Year†

## SPECIFICATIONS

**INPUT SIGNALS:** Current, voltage or resistance  
**POWER REQUIREMENTS:** 115/230 Vac or 11 Vdc to 36 Vdc  
**INTERNAL POWER SUPPLY:** 24 Vdc  
**ELECTRICAL CONNECTION:** Terminal blocks in rear  
**UPDATE RATE:** Up to 20 times per second adjustable (Up to 105 time per second, adjustable for 2100 Series)  
**LINEARIZATION:** 16 point scaling of non linear input  
**ACCURACY:**  $\pm 0.03\%$  of reading +3  $\mu$ A for 4 mA to 20 mA input;  $\pm 0.03\%$  of reading +3 mV for 0 to 5 Vdc and 0 Vdc to 10 Vdc inputs over the range of 18 °C to 28 °C

CE Compliant to EMC norm EN61326:1997/A1:1998 RFI, EMI, ESD protection; NEMA 4X/IP65 sealed bezel only



## 2000/2100 SERIES

### NOSHOK SMART SYSTEM "INTELLIGENT" DIGITAL INDICATORS

are field upgradeable digital process indicators with single or dual input which suit a wide range of indication and control requirements. They can accept a variety of standard process signals and precisely scale them into any desired unit of measure. The indicator employs advanced technology for stable, drift free readout, while incorporating added features such as an optional analog output card, dual or quad relay cards or serial communication cards. The easy menu driven programming or available PC software allows the user to quickly and easily set system configurations.

**WARRANTY:** One Year†

## SPECIFICATIONS

**OUTPUT SIGNAL:** 4 mA to 20 mA, 2-wire  
**RANGES:** STD gauge ranges from vacuum to 15,000 psi. Absolute ranges also available  
**ACCURACY:**  $\pm 0.5\%$  Full Scale (B.F.S.L.);  $\pm 1.0\%$  Terminal Point; Optional  $\pm 0.25\%$  Full Scale (B.F.S.L.),  $\pm 0.5\%$  Terminal Point  
**HOUSING MATERIAL:** 316 stainless steel  
**POWER SUPPLY:** 10 Vdc to 30 Vdc, unregulated  
**ADJUSTMENT:**  $\pm 10\%$  for zero and span

CE compliant to EMC norm EN 61326: 1997/A1 1998  
 RFI, EMI and ESD protection  
 IP65, NEMA 4X to EN 60529/IEC 529



## 100 SERIES



**NOSHOK CURRENT OUTPUT PRESSURE TRANSMITTERS** are designed utilizing advanced diffused semiconductor and proven sputtered thin film sensor technology for maximum stability. They are highly repeatable, shock resistant and extremely stable over long periods of time. CE compliance, which includes substantial levels of RFI, EMI and ESD protection combined with reverse polarity and over-voltage protection, ensures that these transmitters perform well in the most demanding applications.

**WARRANTY:** Three Years†

## SPECIFICATIONS

**OUTPUT SIGNALS:** 0 to 5 Vdc, 0 to 10 Vdc, 1 to 5 Vdc, 1 to 6 Vdc & 1 to 11 Vdc, 3-wire  
**RANGES:** STD gauge ranges from vacuum to 15,000 psi. Absolute ranges also available  
**ACCURACY:**  $\pm 0.5\%$  Full Scale (B.F.S.L.);  $\pm 1.0\%$  Terminal Point; Optional  $\pm 0.25\%$  Full Scale (B.F.S.L.),  $\pm 0.5\%$  Terminal Point  
**HOUSING MATERIAL:** 316 stainless steel  
**POWER SUPPLY:** 10 Vdc to 30 Vdc, 14 Vdc to 30 Vdc for 1 Vdc to 11 Vdc & 0 Vdc to 10 Vdc, unregulated

CE compliant to EMC norm EN 61326: 1997/A1 1998  
 RFI, EMI and ESD protection  
 IP65, NEMA 4X to EN 60529/IEC 529



## 200 SERIES



**NOSHOK VOLTAGE OUTPUT PRESSURE TRANSDUCERS** are highly repeatable, shock resistant and extremely stable over long periods of time. Utilizing advanced diffused semiconductor and proven sputtered thin film sensor technology they are highly accurate and stable. CE compliant.

**WARRANTY:** Three Years†

## SPECIFICATIONS

**OUTPUT SIGNALS:** 4 mA to 20 mA, 2-wire; 0 Vdc to 5 Vdc, 3-wire; 1 Vdc to 5 Vdc, 3-wire; 0 Vdc to 10 Vdc, 3-wire; .5 Vdc to 4.5 Vdc ratiometric, 3-wire  
**RANGES:** Standard from 0 psig to 15 psig; through 0 psig to 10,000 psig, standard absolute ranges 15 psig through 200 psig  
**ACCURACY:**  $\pm 0.5\%$  full scale (B.F.S.L.);  $\pm 1.0\%$  Terminal Point; Optional  $\pm 0.25\%$  Full Scale (B.F.S.L.),  $\pm 0.5\%$  Terminal Point  
**HOUSING MATERIAL:** 316L stainless steel  
**POWER SUPPLY:** 8 Vdc to 30 Vdc unregulated for 4 mA to 20 mA output, 8 Vdc to 30 Vdc for 0 Vdc to 5 Vdc output; 14 Vdc to 30 Vdc for 0 Vdc to 10 Vdc output and 1 Vdc to 5 Vdc outputs; 5 Vdc  $\pm 0.5$  Vdc for 0.5 Vdc to 4.5 Vdc output

CE compliant to EMC norm EN 61326: 1997/A1 1998  
 RoHS Compliant



## 300 SERIES



**NOSHOK COMPACT OEM PRESSURE TRANSDUCERS'** rugged, compact design delivers solid durability and long term stability during operation. Engineered for use in general industrial applications, it features technical specifications exceeding those of competitors' transducers costing much more. A wide variety of electrical and mechanical connections are available for easy installation into most applications, along with most popular analog output signals. All electrical components carry a high degree of EMC protection compliant with EN 61326, which makes it ideal for areas where RFI, EMI or ESD signals are present. Its high quality stainless steel construction is compatible with chemically aggressive media. The sensor is welded directly to the process connection, eliminating the need for gaskets or seals while also increasing its resistance to mechanical stress.

**WARRANTY:** Three Years†

## SPECIFICATIONS

**OUTPUT SIGNALS:** 4 mA to 20 mA, 2-wire & 0 to 5 Vdc, 0 to 10 Vdc, 0.5 to 2.5 Vdc, 3-wire  
**RANGES:** 0 to 50 inH<sub>2</sub>O through 0 to 1000 psi  
**CABLE:** Durable high performance Polyurethane jacketed cable enhances reliability; Teflon and Water-blocked PVC cable optional  
**ACCURACY:**  $\pm 0.25\%$  Full Scale (B.F.S.L.);  $\pm 0.5\%$  Terminal Point; Optional  $\pm 0.125\%$  Full Scale (B.F.S.L.),  $\pm 0.25\%$  Terminal Point  
**HOUSING MATERIAL:** 316 stainless steel  
**POWER SUPPLY:** 10 Vdc to 30 Vdc for Current Output, 14 Vdc to 30 Vdc for 0 Vdc to 10 Vdc; 5 Vdc to 30 Vdc for 0.5 Vdc to 2.5 Vdc

CE compliant to EMC norm EN 61326: 1997/A1 1998  
 RFI, EMI and ESD protection  
 IP68, NEMA 6P



## 612 SERIES



**NOSHOK SUBMERSIBLE LEVEL TRANSMITTERS** offer a previously unequalled level of performance. Utilizing diffused semiconductor and proven sputtered thin film sensor technology they are highly accurate, shock resistant and extremely stable for long periods of time. Reverse polarity protection and short circuit protection have been installed as standard features. Lightning protection is optional.

**WARRANTY:** Three Years†

## SPECIFICATIONS

**OUTPUT SIGNALS:** 4 mA to 20 mA, 2-wire: 0 to 5 Vdc, 0 to 10 Vdc, 1 to 5 Vdc, 1 to 6 Vdc & 1 to 11 Vdc, 3-wire  
**RANGES:** STD gauge ranges from vacuum to 120,000 psi. Absolute ranges also available  
**ACCURACY:** ±0.25% Full Scale (B.F.S.L.); ±0.5% Terminal Point; Optional ±0.125% Full Scale (B.F.S.L.), ±0.25% Terminal Point  
**POWER SUPPLY:** 10 Vdc to 30 Vdc for Current Output, 14 Vdc to 30 Vdc for Voltage Output

CE compliant to EMC norm EN 61326: 1997/A1  
 1998 RFI, EMI and ESD protection IP65, NEMA 4X  
 to EN 60529/IEC 529



## 615/616 SERIES



**NOSHOK HIGH ACCURACY HEAVY DUTY PRESSURE TRANSDUCERS** are designed for heavy duty applications requiring high accuracy and durability. Utilizing advanced diffused semiconductor and proven sputtered thin film sensor technology they are stable, accurate, shock resistant and extremely durable. The durability is coupled with the mechanical integrity of the case, process connection, and wetted parts constructed of corrosion-resistant stainless steel.

**WARRANTY:** Three Years†

## SPECIFICATIONS

**OUTPUT SIGNALS:** 4 mA to 20 mA or 1 Vdc to 5 Vdc or 0.5 Vdc to 4.5 Vdc Low Power Outputs  
**RANGES:** From vacuum to 15,000 psi-gauge, compound or absolute  
**ACCURACY:** ±0.25% Full Scale (B.F.S.L.); ±0.5% Terminal Point  
**CONNECTION:** 1/2 inch NPT male conduit electrical connection  
**POWER SUPPLY:** 10 Vdc to 30 Vdc unregulated for 4 mA to 20 mA output, 6 Vdc to 30 Vdc for 1 Vdc to 5 Vdc low power and 0.5 Vdc to 4.5 Vdc low power (≤ 2 mA for power supply ≤ 12 Vdc) output

FM and CSA approved; XP / Class I / Division 1 / Groups A, B, C and D; DIP / Class II and III / Division 1 / Groups E, F and G

CE compliant to EMC norm EN 61326: 1997/A1  
 1998 RFI, EMI and ESD protection / ANSI/ISA-12.27.01-2003 approved single seal



## HAZARDOUS LOCATION PRESSURE TRANSMITTERS

## 621/622 SERIES



**NOSHOK EXPLOSION PROOF PRESSURE TRANSDUCERS** are designed for applications that require pressure measurement in hazardous environments. They combine proven sputtered thin film sensor technology or the reliable, long life diffused semiconductor with safe electronics to provide outstanding performance and value in a hazardous location transmitter. All wetted parts are made of stainless steel and Elgiloy welded with no internal O-rings, gaskets or seals.

**619/620 Series available with ATEX Approval.**



**WARRANTY:** Three Years†

## SPECIFICATIONS

**OUTPUT SIGNALS:** 4 mA to 20 mA or 1 Vdc to 5 Vdc or 0.5 Vdc to 4.5 Vdc Low Power Outputs  
**RANGES:** From vacuum to 15,000 psi-gauge, compound or absolute  
**ACCURACY:** ±0.25% Full Scale (B.F.S.L.); ±0.5% Terminal Point  
**POWER SUPPLY:** 10 Vdc to 30 Vdc unregulated for 4 mA to 20 mA; 6 Vdc to 30 Vdc for 1 Vdc to 5 Vdc, and 0.5 Vdc to 4.5 Vdc output

FM and CSA approved; NI / Class I / Division 2 / Groups A, B, C and D; DIP / Class II / Division 1 / Groups E, F and G

CE compliant to EMC norm EN 61326: 1997/A1  
 1998 RFI, EMI and ESD protection / ANSI/ISA-12.27.01-2003 approved single seal



## HAZARDOUS LOCATION PRESSURE TRANSMITTERS

## 623/624 SERIES



**NOSHOK NON-INCENDIVE PRESSURE TRANSDUCERS** combine advanced diffused semiconductor and proven sputtered thin film sensor technology with safe electronics for outstanding performance and value in a hazardous environment pressure transmitter. The wetted parts are made of stainless steel and a welded pressure chamber with no internal O-rings, gaskets or seals.

**WARRANTY:** Three Years†

## SPECIFICATIONS

**OUTPUT SIGNALS:** 4 mA to 20 mA, 2-wire output signal  
**RANGES:** From vacuum to 60,000 psi-gauge, compound or absolute  
**WETTED PARTS:** Constructed of stainless steel (Hastelloy C4 optional on front flush), welded with no internal O-rings, gaskets or seals  
**ACCURACY:** ±0.25% Full Scale (B.F.S.L.); ±0.5% Terminal Point; Optional ±0.125% Full Scale (B.F.S.L.), ±0.25% Terminal Point  
**POWER SUPPLY:** 10 Vdc to 30 Vdc unregulated, Minimum voltage across transmitter connections is 10 Vdc

FM and CSA approved; IS / Class I, II and III / Division 1 / Groups A, B, C, D, E, F and G; Class I / Zone 0 / AEx ia / Group IIC; DIP / Class II and III / Division 2 / Groups F and G; NI / Class I / Division 2 / Groups A, B, C and D

CE compliant to EMC norm EN 61326: 1997/A1  
 1998 RFI, EMI and ESD protection / ANSI/ISA-12.27.01-2003 approved single seal



## HAZARDOUS LOCATION PRESSURE TRANSMITTERS

## 625/626 SERIES



**NOSHOK INTRINSICALLY SAFE PRESSURE TRANSMITTERS** combine the reliability and long life of diffused semiconductor and proven sputtered thin film sensor technology with safe electronics for outstanding performance and value. These transmitters were designed for applications that require pressure measurement in hazardous locations. They are available in a wide variety of pressure connections, ranges and electrical connections to suit most applications.

**WARRANTY:** Three Years†

† For further warranty information please consult your specific product catalogs.

## HAZARDOUS LOCATION PRESSURE TRANSMITTERS

### SPECIFICATIONS

**OUTPUT SIGNALS:** 4 mA to 20 mA, 2-wire output signal  
**RANGES:** From 50 inH<sub>2</sub>O to 350 psig  
**CABLE:** Durable high performance Polyurethane jacketed cable enhances reliability; Teflon cable optional  
**ACCURACY:** ±0.25% Full Scale (B.F.S.L.), ±0.5% Terminal Point; Optional ±0.125% Full Scale (B.F.S.L.), ±0.25% Terminal Point for ≥150 in H<sub>2</sub>O only  
**POWER SUPPLY:** 10 Vdc to 30 Vdc unregulated

CE Compliant to EMC norm EN 61326; 1997/A1 1998 RFI, EMI and ESD

FM and CSA approved; IS / Class I, II and III / Division 1 / Groups A, B, C, D, E, F and G; Class I / Zone 0 / AEx ia / Group IIC; DIP / Class II and III / Division 2 / Groups F and G; NI / Class I / Division 2 / Groups A, B, C and D



### 627 SERIES



**NOSHOK INTRINSICALLY SAFE SUBMERSIBLE LEVEL TRANSMITTERS** combine the reliability and long life of diffused semiconductor or proven sputtered thin film strain gage sensors with safe electronics to provide outstanding performance and value in a liquid level transmitter designed for hazardous environments. They are available with a stainless steel nosecone, weighted stainless steel nosecone or NPT adapter and ranges to suit most applications.

WARRANTY: Three Years†

### SPECIFICATIONS

**OUTPUT SIGNALS:** 0 Vdc to 5 Vdc, 0 Vdc to 10 Vdc, 1 Vdc to 5 Vdc, 3-wire; 0.5 Vdc to 4.5 Vdc, 3-wire ratio-metric  
**RANGES:** Vacuum and compound through 300 psi  
**ACCURACY:** ±0.5% Full Scale (B.F.S.L.)  
**HOUSING MATERIAL:** Copper alloy with Polyamid cap  
**POWER SUPPLY:** 9 Vdc to 30 Vdc for 0 Vdc to 5 Vdc & 1 Vdc to 5 Vdc; 12 Vdc to 30 Vdc for 0 Vdc to 10 Vdc; 5 Vdc ±10% for 0.5 Vdc to 4.5 Vdc

CE compliant to EMC norm EN 61326: 1997/A1 1998 RFI, EMI and ESD protection IP67, NEMA 4X to EN 60529/IEC 529



### 630 SERIES



**NOSHOK HALL EFFECT TRANSDUCERS** utilize a proven Hall Effect sensor to provide excellent performance and reliability at an economical price. The nearly frictionless transduction method provides exceptional repeatability and long service life.

WARRANTY: Three Years†

### SPECIFICATIONS

**OUTPUT SIGNALS:** 4 mA to 20 mA, 2-wire & 0 to 5 Vdc, 0 Vdc to 10 Vdc, 0.5 to 2.5 Vdc, 3-wire, RS232  
**RANGES:** STD gauge ranges from vacuum to 15,000 psi. Absolute ranges also available  
**ACCURACY:** ±0.05% Full Scale (B.F.S.L.); ±0.1% Terminal Point; Optional ±0.025% Full Scale (B.F.S.L.), ±0.05% Terminal Point  
**POWER SUPPLY:** 10 Vdc to 30 Vdc for Current Output, 14 Vdc to 30 Vdc for 0 Vdc to 10 Vdc Output; Voltage supply from interface RS232-C

CE compliant to EMC norm EN 61326: 1997/A1 1998 RFI, EMI and ESD IP65, NEMA 4X (IEC 529)



### 640 SERIES



**NOSHOK PRECISION HEAVY DUTY PRESSURE TRANSDUCERS WITH SERIAL INTERFACE** have been designed for industrial and laboratory applications requiring high accuracy and repeatability with excellent compensation for temperature.

WARRANTY: Three Years†

### SPECIFICATIONS

**OUTPUT SIGNALS:** 4 mA to 20 mA, 2-wire; 0 to 10 Vdc, 1 to 5 Vdc, 3-wire; 0.5 Vdc to 4.5 Vdc, 3-wire ratio-metric  
**RANGES:** 0 to 100 psig to 0 to 8,000 psig  
**ACCURACY:** ±0.5% Full Scale (B.F.S.L.) ±1.0% Terminal Point  
**POWER SUPPLY:** 10 Vdc to 36 Vdc for 4 mA to 20 mA & 1 Vdc to 5 Vdc; 14 Vdc to 36 Vdc for 0 Vdc to 10 Vdc; 5 Vdc ±0.5 Vdc for 0.5 Vdc to 4.5 Vdc

CE compliant to EMC norm EN 61326: 1997/A1 1998 RFI, EMI and ESD



### 650 SERIES



**NOSHOK HIGH VOLUME OEM PRESSURE TRANSDUCERS** combine high performance with off road vehicle reliability under severe process and environmental conditions. They are designed to handle high pressure spikes and process pulsation. Utilize advanced diffused semiconductor and proven sputtered thin film sensor technology for maximum stability.

WARRANTY: Three Years†

## SPECIFICATIONS

**OUTPUT SIGNAL:** 4 mA to 20 mA 2-wire, 1 Vdc to 5 Vdc, and 0.1 Vdc to 10 Vdc 3-wire  
**RANGES:** Standard ranges from 200 psig to 15,000 psig  
**ACCURACY:** ±0.25% Full Scale (B.F.S.L.); ±0.5% Terminal Point  
**POWER SUPPLY:** 10 Vdc to 30 Vdc for 4 mA to 20 mA; 14 Vdc to 30 Vdc for 1 Vdc to 5 Vdc, & 0.1 Vdc to 10 Vdc 3-wire

CE compliant to EMC norm EN 61326: 1997/A1 1998  
 RFI, EMI and ESD IP65, NEMA 4X (IEC 529)



## 660 SERIES



**NOSHOK MICRO-SIZE PRESSURE TRANSDUCERS** are designed with high overpressure capability to provide long service life and reliability in hydraulic and pneumatic applications containing process pulsations and high vibration. Utilizes proven sputtered thin film sensor technology for maximum stability and accuracy.

**WARRANTY:** Three Years†

## SPECIFICATIONS

**OUTPUT SIGNAL:** 4 mA to 20 mA, 2-wire  
**RANGES:** STD gauge ranges from vacuum through 15,000 psig  
**ACCURACY:** ±0.05% Full Scale (B.F.S.L.); ±0.1% Terminal Point; ±0.15% Full Scale (B.F.S.L.) for 0 to 15,000 psig range; ±0.3% Terminal Point  
**POWER SUPPLY:** 10 Vdc to 30 Vdc, unregulated  
 • Built in process temperature display  
 • Built in selectable process digital filtering  
 • 32 point process linearization

CE compliant to EMC norm EN 61326: 1997/A1 1998 RFI, EMI and ESD



## 755/756 SERIES



**NOSHOK HIGH PERFORMANCE DIGITAL PRESSURE TRANSMITTERS** combine advanced diffused semiconductor and proven sputtered thin film sensor technology with digital electronics for outstanding performance and value. They offer maximum flexibility with up to 20:1 span turn down and -2.5 to 99% zero adjustment.

**WARRANTY:** Three Years†

# PRESSURE SWITCHES

## SPECIFICATIONS

**CASE:** Brass standard, stainless steel optional  
**MEASURING ELEMENT:** NBR Diaphragm standard – Viton®, EPDM optional  
**SWITCHING FUNCTION:** 1 SPST N.O. or 1 N.C.  
**ADJUSTMENT:** Adjustment screw from 5 psig to 150 psig depending on full scale range  
**AVAILABLE RANGES:** 0 psig to 30 psig through 0 psig to 150 psig  
**CONNECTION:** 1/8 inch NPT, male  
**ELECTRICAL CONNECTION:** 6.3mm spade terminals  
**MEDIA TEMPERATURE:** -13 °F to 185 °F (-25 °C to 85 °C)

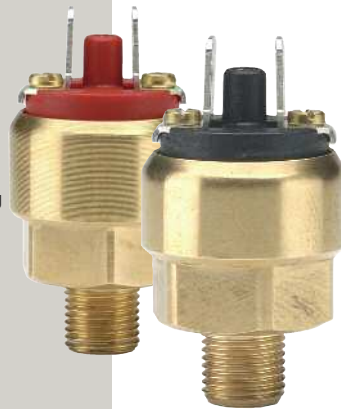

## 100 SERIES

**NOSHOK MECHANICAL PRESSURE SWITCHES** are constructed of a solid one-piece housing, making them highly durable for use in the most rugged applications. The compact design allows it to be installed where space is limited. These switches utilize a proven diaphragm-type sensing element, and have an external adjustment screw for ease of setting the switching point on-site. Special versions are available with the alternate diaphragm, housing and contact materials to meet most current requirements. 100 Series is the ideal choice when reliability, accuracy and cost efficiency are a priority.

**WARRANTY:** One Year†

## SPECIFICATIONS

**CASE:** Zinc-plated steel  
**MEASURING ELEMENT:** NBR diaphragm < 225 psig; Steel piston with NBR seal > 225 psig  
**SWITCHING FUNCTION:** SPDT, micro switch with silver plated contacts, gold plated contacts available on request  
**ADJUSTMENT:** Adjustment screw from 3 psig to 4600 psig depending on full scale range  
**AVAILABLE RANGES:** 3 psig to 30 psig through 450 psig to 4600 psig  
**CONNECTION:** 1/4 inch NPT standard, others available on request  
**ELECTRICAL CONNECTION:** 6.3mm spade terminals  
**MEDIA TEMPERATURE:** -4°F to 176°F (-20°C to 80°C)



## 200 SERIES



**NOSHOK MECHANICAL PRESSURE SWITCHES** operate using a high quality diaphragm or piston element to open or close a micro switch, and provide maximum versatility, excellent repeatability and superior contact ratings. These compact-sized switches have a frequency of 100 cycles per minute, and switching repeatability of ±2.0%. They also feature superior contact ratings: AC up to 250 V - 4 A, and DC up to 28 V - 2 A, and are RoHS compliant. This switch features an SPDT (single changeover) contact configuration. Ranges are available from 3 psig to 30 psig through 450 psig to 4600 psig, and an external adjustment screw allows for ease of setting the switching point on-site. Available in special versions with stainless steel or brass housing and gold contacts for low switching currents

**WARRANTY:** One Year†

† For further warranty information please consult your specific product catalogs.



## SPECIFICATIONS

**CASE:** Zinc plated steel  
**MEASURING ELEMENT:** NBR diaphragm < 225 psig; Steel piston with NBR seal > 225 psig  
**SWITCHING FUNCTION:** SPDT, micro switch with silver plated contacts, gold plated contacts available on request  
**ADJUSTMENT:** Adjustment screw from 3 psig to 4600 psig depending on full scale range  
**AVAILABLE RANGES:** 3 psig to 30 psig through 450 psig to 4600 psig  
**CONNECTION:** 1/4 inch NPT standard, others available on request  
**ELECTRICAL CONNECTION:** Hirschmann (DIN EN 175301-803)  
**MEDIA TEMPERATURE:** -4°F to 176°F (-20°C to 80°C)

CE compliant to EMC norm EN 61326: 1997/A1 1998 RFI, EMI and ESD



## 300 SERIES

**NOSHOK MECHANICAL PRESSURE SWITCHES** are constructed with a rugged zinc plated steel housing and process connection, and provide adjustable hysteresis (10-30% of switch point). Utilizing a proven diaphragm or piston type sensing technology, it provides excellent reliability, repeatability, and affordability for use in many applications. The micro switch contacts are silver plated for extended service life and exceptional dependability. Switching functions are field adjustable, while under pressure, and it features an SPDT single changeover contact configuration. These switches are RoHs compliant.

**WARRANTY:** One Year†

## SPECIFICATIONS

**CASE:** Zinc-plated steel  
**WETTED PARTS:** Zinc-plated steel; NBR diaphragm <230 psig, Stainless steel piston with NBR seal >500 psig  
**CONNECTION:** 1/4 inch NPT and 7/16-20 SAE – STD  
**ELECTRICAL CONNECTION:** Hirschmann (DIN 43650 A)  
**REPEATABILITY:** ±2% Full Scale  
**AVAILABLE RANGES:** 0 psig to 300 psig through 0 psig to 5,000 psig  
**SWITCHING FUNCTIONS:** SPDT, micro-switch with silver-plated contacts

CE Compliant to EMC norm 61326: 1997/A1 1998 RFI, EMI and ESD



## 400 SERIES

**NOSHOK MECHANICAL BLOCK TYPE SWITCH** provides excellent repeatability and features a robust design for applications requiring maximum accuracy under extreme loads. With a switching point setting that remains stable for years, this switch converts pneumatic and hydraulic pressure into switching functions, and depending on the type of connection, it can easily be used as a N.C., N.O. or SPDT contact. The switching point is fully adjustable and includes a locking mechanism. This switch is fitted with 43650 DIN connectors for fast and easy installation. It is also available with a socket with an LED for easier switch point adjustment and visual status indication, or without the socket and an M12 x 1 electrical connection.

**WARRANTY:** Three Years†

## SPECIFICATIONS

**CASE:** Brass through 350 psi; aluminum 600 psi and higher  
**WETTED PARTS:** Copper alloy; 316 stainless steel above 600 psig  
**CONNECTION:** 1/4 inch NPT, brass  
**ELECTRICAL CONNECTION:** M12 x 1 (4-Pin)  
**REPEATABILITY:** ≤1% full scale  
**AVAILABLE RANGES:** Vacuum through 0 to 15,000 psi  
**SWITCHING FUNCTIONS:** 1 N.O. or 1 N.C. contact standard, 2 N.O. or 2 N.C. contacts are optional, p-switching or n-switching

CE compliant to EMC norm EN 61326: 1997/A1 1998 RFI, EMI and ESD



## 500 SERIES

**NOSHOK MAG-SWITCH** is an electronic pressure switch that utilizes proven diaphragm pressure sensing technology coupled with Hall Effect magnetic field sensing technology and semiconductor switching technology to provide a highly reliable, accurate, repeatable pressure switch without mechanical contacts. The standard electrical connection is a 4-pin M12 X 1 threaded connector which carries a NEMA 4: IP65 (IEC529) rating.

**WARRANTY:** Three Years†

## SPECIFICATIONS

**CASE:** 316 stainless steel  
**WETTED PARTS:** 316 stainless steel  
**CONNECTION:** 1/4 inch NPT – STD; 1/2 inch NPT – Optional  
**ELECTRICAL CONNECTION:** M12 x 1 (4-Pin)  
**ACCURACY:** ≤1% full scale (limit point setting); ≤0.5% (B.F.S.L.)  
**AVAILABLE RANGES:** Vacuum, compound, 0 to 5 psi through 0 to 15,000 psi and absolute  
**SWITCHING FUNCTIONS:** 1 or 2; N.O. or N.C.; p or n-switching  
**POWER SUPPLY:** 10 Vdc to 30 Vdc (>12 Vdc for programming mode); Increase time when switching on the supply 50 V/sec

CE compliant to EMC norm EN 61326: 1997/A1 1998 RFI, EMI and ESD



## 600 SERIES

**NOSHOK SMART SWITCH** is a truly state-of-the-art pressure switch. Its design is based upon the proven sputtered thin film and diffused semiconductor sensor technology. Switching is accomplished digitally with an integral signal conditioner, which means there are never any mechanical contacts to wear out. Set points and hysteresis are fully adjustable and completely tamperproof. Programming can be done at the factory or in the field with NOSHOK Smart Switch Software.

**WARRANTY:** Three Years†

## SPECIFICATIONS

**CASE:** Series 800 - stainless steel, Series 810 – black anodized aluminum  
**WETTED PARTS:** Stainless steel with ceramic sensor and Viton® seal on ranges through 0 psig to 230 psig (other sealing materials available, stainless steel only for higher pressure ranges).  
**CONNECTION:** 1/4 inch NPT standard, other options available  
**ELECTRICAL CONNECTION:** M12 x 1 (4-Pin)  
**ACCURACY:** <0.5% full scale (B.F.S.L.)  
**AVAILABLE RANGES:** Standard -14.5 psig to 30 psig through 0 psig to 9999 psig  
**SWITCHING FUNCTIONS:** 1 or 2 N.O. or N.C. (PNP or NPN)  
**POWER SUPPLY:** 12 Vdc to 30 Vdc  
**ANALOG OUTPUT:** 4 mA to 20 mA or 0 Vdc to 10 Vdc; programmable and freely adjustable

CE compliant to EMC norm EN 61326: 1997/A1 1998 RFI, EMI and ESD



## 800/810 SERIES

**NOSHOK'S ELECTRONIC PRESSURE SWITCH/ TRANSMITTERS** are available with 2 switching outputs, 1 switching output and 1 analog output (4–20 mA or 0–10 V), or 2 switching outputs and 1 analog output (4–20 mA). These pressure switch/transmitters provide continuous pressure monitoring and allow the programming of set points without pressurizing. Two buttons allow easy adjustment of the set points, contact functions (normally open/normally closed), reset points, contact types (npr/pnp) and switching function (hysteresis/gate). Other features include integrated password protection, and a higher maximum pressure than anything comparable on the market (9999 psi). The 800/810's convenient 330° rotatable indicator head and optional turntable process connection provide ease of installation and wiring.

**WARRANTY:** Three Years†

† For further warranty information please consult your specific product catalogs.

**CAUTION:** NOSHOK pressure transmitters are not to be used in heat sterilization systems as stated in 3A Standard 74-03 paragraph D10.1.2. Diaphragm seal must be installed facing downward or in a vertical position for drainability. Do not install diaphragm seal facing in an upward position.

## SPECIFICATIONS

**SIZE:** 2 inch  
**CASE MATERIAL:** 304 stainless steel  
**COVER RING:** 304 stainless steel  
**LENS:** Polycarbonate – STD; safety glass – Optional  
**BOURDON TUBE:** 316 stainless steel  
**ACCURACY:** ±2.5% Full Scale  
**PROCESS CONNECTION:** 3/4 inch Tri-Clamp®  
**SEAL HOUSING:** 316L stainless steel  
**DIAPHRAGM MATERIAL:** 316L stainless steel  
**SEAL FILL:** Glycerine, USP grade  
**RANGES:** 0 to 15 psig through 0 to 600 psig  
**TEMPERATURE:** -40 °F to 300 °F (-40 °C to 150 °C)



## 10 SERIES FRACTIONAL



**NOSHOK FRACTIONAL SANITARY GAUGE** is designed for compact applications within the food & beverage, dairy, pharmaceutical, and biomedical industry while meeting the current 3A standards and ASME BPE-2009. The wetted materials are electropolished 316L stainless steel to Ra25 microinch or better. Gauges can be cleaned in place (CIP), steamed in place (SIP) or autoclaved to reduce system shutdown time.

**WARRANTY:** (dry): One Year†; (liquid filled): Three Years†

## SPECIFICATIONS

**SIZE:** 2-1/2 inch or 4 inch  
**CASE MATERIAL:** 304 stainless steel  
**COVER RING:** 304 stainless steel  
**LENS:** Safety glass – STD  
**BOURDON TUBE:** 316 stainless steel  
**ACCURACY:** ±1.5% Full Scale on 2-1/2 inch sizes; ±1 % Full Scale on 4 inch sizes  
**OPTIONAL FILL FLUID:** glycerine or silicone  
**PROCESS CONNECTION:** 1-1/2 inch or 2 inch Tri-Clamp®  
**SEAL HOUSING:** 316L stainless steel  
**DIAPHRAGM MATERIAL:** 316L stainless steel  
**SEAL FILL:** Glycerine, USP grade  
**RANGES:** Vacuum and compound through 0 to 600 psig  
**TEMPERATURE:** -40 °F to 300 °F (-40 °C to 150 °C)



## 10 SERIES HEAVY DUTY



**NOSHOK HEAVY DUTY SANITARY PRESSURE GAUGE** meets the current standards for 3A and ASME BPE-2009. They are designed for applications throughout the pharmaceutical industry, food & beverage, dairy and biomedical industries. The available 1-1/2 or 2 inch Tri-Clamp® connections are constructed of 316L stainless steel welded to the all stainless steel 2-1/2 inch or 4 inch gauge for greater strength and durability. Wetted parts are electropolished to Ra 25 microinch or better.

**WARRANTY:** (dry): One Year†; (liquid filled): Three Years†

\*C.I.P, S.I.P and Autoclave

## SPECIFICATIONS

**OUTPUT SIGNALS:** 4 mA to 20 mA, 2-wire: 0 Vdc to 5 Vdc, 0 to 10 Vdc, 1 Vdc to 5 Vdc, 1 Vdc to 6 Vdc & 1 Vdc to 11 Vdc, 3-wire  
**ACCURACY:** ±0.25% Full Scale (B.F.S.L.); ±0.5% Terminal Point; Optional ±0.125% Full Scale (B.F.S.L.), ±0.25% Terminal Point  
**POWER SUPPLY:** 10 Vdc to 30 Vdc for Current Output, 14 Vdc to 30 Vdc for Voltage Output  
**PROCESS CONNECTION:** 1-1/2 inch or 2 inch Tri-Clamp®  
**SEAL HOUSING:** 316L stainless steel  
**DIAPHRAGM MATERIAL:** 316L stainless steel  
**SEAL FILL:** White oil, USP grade  
**RANGES:** Vacuum and compound through 0 to 400 psig  
**TEMPERATURE:** -40 °F to 300 °F (-40 °C to 150 °C)



## 11 SERIES



**NOSHOK HIGH ACCURACY, HEAVY DUTY SANITARY TRANSMITTER** utilizes diffused semiconductor and proven sputtered thin film sensor technology to produce a highly accurate, stable, shock resistant and durable pressure transmitter. They are suited for applications in the food & beverage, dairy, biotechnology and pharmaceutical industries and meet the current 3A standards as well as ASME BPE-2009 and CE compliant. Wetted parts are 316L stainless steel and electropolished to Ra 25 or better. Can be cleaned in place (CIP) and steamed in place (SIP).

**WARRANTY:** Three Years†

CE compliant to EMC norm EN 61326: 1997/A1 1998 RFI, EMI and ESD

## SPECIFICATIONS

**SIZE:** 4 inch  
**CASE MATERIAL:** 304 stainless steel  
**COVER RING:** 304 stainless steel  
**LENS:** Laminated safety glass – STD  
**BOURDON TUBE:** 316 stainless steel  
**ACCURACY:** ±1 % Full Scale  
**OPTIONAL FILL FLUID:** Glycerine or silicone  
**PROCESS CONNECTION:** 1-1/8 inch homogenizer flange  
**SEAL HOUSING:** 316L stainless steel  
**DIAPHRAGM MATERIAL:** 316L stainless steel  
**SEAL FILL:** Glycerine, USP grade  
**RANGES:** 0 to 1,000 psig through 0 to 15,000 psig  
**TEMPERATURE:** -40 °F to 300 °F (-40 °C to 150 °C)



## 20 SERIES



**NOSHOK SANITARY HOMOGENIZER GAUGE** meets the current 3A standards and ASME BPE-2009. They are designed for high pressure applications in the dairy, food & beverage, pharmaceutical and biotechnology industries. The 4 inch all stainless steel gauge is welded to the flanged homogenizer connection. Wetted parts are 316L stainless steel and electropolished to Ra 25 or better. These gauges may be cleaned in place (CIP), steamed in place (SIP) or autoclaved to reduce process shutdown time.

**WARRANTY:** (dry): One Year†; (liquid filled): Three Years†

## SPECIFICATIONS

**OUTPUT SIGNALS:** 4 mA to 20 mA, 2-wire: 0 Vdc to 5 Vdc, 0 Vdc to 10 Vdc, 1 Vdc to 5 Vdc, 1 Vdc to 6 Vdc & 1 Vdc to 11 Vdc, 3-wire  
**RANGES:** STD gauge ranges from vacuum to 120,000 psi. Absolute ranges also available  
**ACCURACY:** ±0.25% Full Scale (B.F.S.L.); ±0.5% Terminal Point; Optional ±0.125% Full Scale (B.F.S.L.), ±0.25% Terminal Point  
**POWER SUPPLY:** 10 Vdc to 30 Vdc for Current Output 14 Vdc to 30 Vdc for Voltage Output  
**PROCESS CONNECTION:** 1-1/8 inch homogenizer flange  
**SEAL HOUSING:** 316L stainless steel  
**DIAPHRAGM MATERIAL:** 316L stainless steel  
**SEAL FILL:** White oil, USP grade  
**RANGES:** 0-1,000 psig through 0-15,000 psig  
**TEMPERATURE:** -40 °F to 300 °F (-40 °C to 150 °C)



## 21 SERIES



**NOSHOK SANITARY HOMOGENIZER TRANSMITTER** is a high accuracy, heavy duty transmitter that utilizes proven sputtered thin film sensor technology to meet the demands of the dairy, food & beverage and pharmaceutical industries. These transmitters are shock resistant, highly accurate, stable and durable and meet the current standards for 3A, CE compliance and ASME BPE-2009. Wetted parts are 316L stainless steel and electropolished to Ra 25 or better. Can be cleaned in place (CIP) and steamed in place (SIP).

**WARRANTY:** Three Years†

CE compliant to EMC norm EN 61326: 1997/A1 1998 RFI, EMI and ESD

† For further warranty information please consult your specific product catalogs.

## SPECIFICATIONS

**LOWER HOUSING:** All metallic  
**UPPER HOUSING:** Carbon steel or 316 stainless steel  
**DIAPHRAGM MATERIALS:** All metallic or elastomers  
**O-RING:** Buna-N®, Teflon®, Viton®  
**BOLTING:** Carbon steel or 300 stainless steel series



## TYPE 10

**NOSHOK STANDARD PRESSURE REPLACEABLE DIAPHRAGM SEALS** are designed to utilize a replaceable diaphragm clamped between the metal housings. They are rated to 2,000 psi with a displacement capability of 0.09 cubic inches.

**WARRANTY:** One Year†

## SPECIFICATIONS

**LOWER HOUSING:** All non-metallic  
**UPPER HOUSING:** Carbon steel or 316 stainless steel  
**DIAPHRAGM MATERIALS:** All metallic or elastomers  
**O-RING:** Buna-N®, Teflon®, Viton®  
**BOLTING:** Carbon steel or 300 stainless steel series



## TYPE 10L

**NOSHOK NON-METALLIC LOWER HOUSING, REDUCED PRESSURE REPLACEABLE DIAPHRAGM SEALS** utilize a replaceable diaphragm and non-metallic lower housing. They are rated to 200 psi with a displacement capability of 0.09 cubic inches.

**WARRANTY:** One Year†

## SPECIFICATIONS

**LOWER HOUSING:** All metallic  
**UPPER HOUSING:** Carbon steel or 316 stainless steel  
**DIAPHRAGM MATERIALS:** All metallic  
**O-RING:** Buna-N®, Viton®  
**BOLTING:** Carbon steel or 300 stainless steel series



## TYPE 10H

**NOSHOK ELEVATED PRESSURE REPLACEABLE DIAPHRAGM SEALS** are a threaded connection, off-line seal with a replaceable diaphragm. They are designed for high pressure applications and are rated to 10,000 psi. Displacement capability is 0.05 cubic inches.

**WARRANTY:** One Year†

## SPECIFICATIONS

**UPPER HOUSING:** 316 stainless steel  
**DIAPHRAGM MATERIALS:** 316 stainless steel  
**STAINLESS STEEL LADISH TRI-CLAMP®:** 1-1/2, 2-1/2 and 3 inch options  
**GASKET:** Buna-N®, Teflon®



## TYPE 12

**NOSHOK TRI-CLAMP® SANITARY PRESSURE DIAPHRAGM SEALS** feature a flush mount diaphragm and all welded construction, making them ideal for food & beverage, pharmaceutical and sanitary markets. They have a minimum working pressure of -30 inHg to 0 psig through -30 inHg to 600 psig, and can accommodate process connection pipes from 1-1/2 inch through 3 inch sizes and 2-1/2, 4-1/2 and 6 inch gauge sizes. Their clamped connection allows ease of installation and removal of seal for maintenance and cleaning.

**CAUTION:** NOSHOK pressure transmitters are not to be used in heat sterilization systems as stated in 3A Standard 74-03 paragraph D10.1.2 Diaphragm seal must be installed facing downward or in a vertical position for drainability. Do not install diaphragm seal facing in an upward position.

**WARRANTY:** One Year†

## SPECIFICATIONS

**HOUSING:** 316 stainless steel  
**DIAPHRAGM MATERIALS:** 316 stainless steel



## TYPE 20

**NOSHOK FRONT FLUSH BUTTON STYLE ALL WELDED DIAPHRAGM SEALS** are constructed with a 316 stainless steel housing and diaphragm. Maximum pressure rating is 9,000 psi. Available instrument connection sizes are 1/4 and 1/2 inch with a process connection size of 1/2 inch NPT male to 2 inch NPT male.

**WARRANTY:** One Year†

## SPECIFICATIONS

**LOWER HOUSING:** 316 stainless steel, Hastelloy C, Carpenter 20 and Monel  
**UPPER HOUSING:** 316 stainless steel, Carpenter 20 and Monel  
**DIAPHRAGM MATERIALS:** 316 stainless steel, Hastelloy C, Carpenter 20 and Monel



## TYPE 25

**NOSHOK STANDARD PRESSURE DIAPHRAGM SEALS** utilize an all welded, all metallic housing design, pressure rated to 2,500 psi. The housing and diaphragm are offered in a variety of materials to suit most applications. A flushing port is offered as an option.

**WARRANTY:** One Year†



## SPECIFICATIONS

**LOWER HOUSING:** 316 stainless steel, Hastelloy C, Carpenter 20 and Monel  
**UPPER HOUSING:** 316 stainless steel, Carpenter 20 and Monel  
**DIAPHRAGM MATERIALS:** 316 stainless steel, Hastelloy C, Carpenter 20 and Monel



## TYPE 25H

**NOSHOK ELEVATED PRESSURE DIAPHRAGM SEALS** utilize an all welded, all metallic housing design pressure rated to 5,000 psi. The housing and diaphragm are offered in a variety of materials to suit most applications. 7A flushing port is offered as an option.

**WARRANTY:** One Year†

## SPECIFICATIONS

**LOWER HOUSING:** 316 stainless steel, Hastelloy C, and Monel  
**UPPER HOUSING:** 316 stainless steel and Monel  
**DIAPHRAGM MATERIALS:** 316 stainless steel, Hastelloy C, and Monel



## TYPE 29

**NOSHOK HIGH DISPLACEMENT DIAPHRAGM SEALS** are an all welded, all metallic housing design that does not utilize an O-ring or gasket. Displacement is limited to 0.035 cubic inches requiring the use of gauges with less than 4-1/2 inch dial size and bourdon tube range no lower than 0 to 15 psi. Pressure rating is 2,500 psi.

**WARRANTY:** One Year†

## SPECIFICATIONS

**LOWER HOUSING:** All metallic  
**UPPER HOUSING:** Carbon steel or 316 stainless steel  
**DIAPHRAGM MATERIALS:** All metallic  
**BOLTING:** Carbon steel or 300 stainless steel series



## TYPE 30

**NOSHOK STANDARD PRESSURE WELDED DIAPHRAGM SEALS** utilize an all metallic diaphragm welded to the upper housing with a displacement capability of 0.05 cubic inches. Standard pressure rating is 2,500 psi with a wide variety of instrument and process connections available. A flushing connection is offered as an option.

**WARRANTY:** One Year†

## SPECIFICATIONS

**LOWER HOUSING:** All metallic  
**UPPER HOUSING:** Carbon steel or 316 stainless steel  
**DIAPHRAGM MATERIALS:** All metallic  
**BOLTING:** Carbon steel or 300 stainless steel series



## TYPE 30H

**NOSHOK ELEVATED PRESSURE WELDED DIAPHRAGM SEALS** utilize an all metallic diaphragm welded to the upper housing with a displacement capability of 0.05 cubic inches. Pressure rating is 5,000 psi to 10,000 psi with a wide variety of instrument and process connections available. A flushing connection is offered as an option.

**WARRANTY:** One Year†

## SPECIFICATIONS

**LOWER HOUSING:** Non-metallic  
**UPPER HOUSING:** Carbon steel or 316 stainless steel  
**DIAPHRAGM MATERIALS:** All metallic  
**BOLTING:** Carbon steel or 300 stainless steel series



## TYPE 30L

**NOSHOK HIGH DISPLACEMENT WELDED DIAPHRAGM SEALS** utilize an all metallic diaphragm welded to the upper housing. Displacement capability is 0.05 cubic inches with a 2.4 inch diameter diaphragm. Maximum pressure rating is 200 psi with non-metallic lower housing materials.

**WARRANTY:** One Year†

# BIMETAL THERMOMETERS AND TEMPERATURE TRANSMITTERS

## SPECIFICATIONS

**SIZE:** 2 inch and 3 inch  
**CASE:** 304 stainless steel  
**BEZEL:** 304 stainless steel  
**LENS:** 2 inch – convex glass; 3 inch – Instrument glass  
**STEM:** 304 stainless steel; 2.5 inch to 24 inch lengths available  
**CONNECTION:** center back – STD; 2 inch – 1/4 inch NPT; 3 inch – 1/2 inch NPT, 3/8 inch NPT - Optional  
**ACCURACY:** 2 inch -  $\pm 1\%$  Full Scale; 3 inch -  $\pm 2\%$  -  $1\%$  -  $2\%$  Full Scale  
**RANGES:** -100 °F to 150 °F through 200 °F to 1,000 °F; (-70 °C to 65 °C through -90 °C to 538 °C); Single and dual scales available



## 100 SERIES



**NOSHOK INDUSTRIAL TYPE BIMETAL THERMOMETERS** are high quality, low cost thermometers designed for limited space applications or where a weather resistant, tamper proof case is required. The bimetal element is an extremely responsive temperature sensing helix which has been carefully sized and tested, heat treated and aged to relieve inherent stresses and insure continued accuracy.

**WARRANTY:** One Year†

## SPECIFICATIONS

**SIZE:** 3 inch and 5 inch  
**CASE:** 304 stainless steel  
**BEZEL:** Electropolished 304 stainless steel  
**LENS:** Instrument glass  
**STEM:** 304 stainless steel; 2.5 inch to 24 inch lengths available  
**CONNECTION LOCATION:** Center back; bottom connection; adjustable angle connection  
**CONNECTION SIZE:** 1/2 inch NPT – STD; 1/4 inch NPT & 3/8 inch NPT – Optional  
**ACCURACY:**  $\pm 1\%$  Full Scale  
**RANGES:** -100 °F to 150 °F through 200 °F to 1,000 °F; Single and Dual Scales available; (-70 °C to 65 °C through -90 °C to 538 °C)

A silicone liquid filled option is available for applications where severe vibration may be a factor.



## 300 SERIES



**NOSHOK INSTRUMENT TYPE BIMETAL THERMOMETERS** are the highest quality thermometers available in today's market. They feature a sturdy, corrosion resistant 304 stainless steel case and bezel which provides a hermetic seal to prevent lens fogging and damage caused by moisture. A slotted hex adjustment head offers field calibration for maximum accuracy at a selected range.

**WARRANTY:** Seven Years†

## SPECIFICATIONS

**OUTPUT SIGNALS:** 4 mA to 20 mA, 2-wire; 0 Vdc to 10 Vdc, 3-wire  
**RANGES:** STD ranges from -40 °F to 1,000 °F; (-40 °C to 538 °C)  
**ACCURACY:** Class B ( $\pm 0.5\%$  Full Scale)  
**POWER SUPPLY:** 10 Vdc to 30 Vdc for Current Output  
14 Vdc to 30 Vdc for Voltage Output  
**HOUSING MATERIAL:** 316 stainless steel  
**WETTED MATERIAL:** 316 stainless steel  
**STEM LENGTHS:** From 2.5 inch to 12 inch – Stock  
**PROCESS CONNECTION:** 1/2 inch NPT male; 1/4 inch NPT available

CE compliant to EMC norm  
EN 61326: 1997/A1 1998  
RFI, EMI and ESD IP65, NEMA 4X (IEC 529)



## 800 SERIES



**NOSHOK PLATINUM RESISTANCE TEMPERATURE TRANSMITTERS** use the proven reliability and stability of the platinum 100 ohm sensor to provide unbeatable performance at an economical price.

**WARRANTY:** Three Years†

## SPECIFICATIONS

**CASE:** Stainless steel  
**WETTED PARTS:** 316Ti stainless steel  
**CONNECTION:** 1/2 inch NPT Male standard, 1/4 inch NPT optional  
**ACCURACY:** Class B +0.1% of the temperature range  
**AVAILABLE RANGES:** Standard ranges from -300 °F to 1,100 °F (-200 °C to 600 °C)  
**SWITCHING FUNCTIONS:** 2 N.O. or N.C. (PNP), 1 N.O. or N.C. (NPN) with 4 mA to 20 mA analog output optional  
**POWER SUPPLY:** 12 Vdc to 30 Vdc  
**ANALOG OUTPUT:** 4 mA to 20 mA, scaleable from 20% to 100% of range  
**ELECTRICAL CONNECTION:** M12 x 1 (4-Pin)

CE compliant to EMC norm EN 61326: 1997/A1 1998  
RFI, EMI and ESD



## 850 SERIES



**NOSHOK ELECTRONIC INDICATING TEMPERATURE SWITCH/TRANSMITTERS** measure and display temperature, and have one or two switching outputs as well as an optional analog output. The two buttons on top allow simple adjustment of the temperature set points, reset points, switching functions and the measuring range of the optional analog output. These extensive features and wide measuring range (between -300 °F and 1100 °F / -200 °C and 600 °C) cover the majority of temperature measuring and switching tasks. A variety of process connections, which are also available as adjustable screw connections, add to the versatility of the NOSHOK 850 Series. For rapid response times, a version with tapered stem is also available. All wetted parts, as well as the housing, are made of stainless steel. The housing and replaceable measuring insert are screwed together to allow the exchange of the measuring insert without opening the connection to the process.

**WARRANTY:** Three Years†

# VAPOR ACTUATED REMOTE THERMOMETERS AND THERMOWELLS

## SPECIFICATIONS

**SIZES:** 2, 2-1/2, 3-1/2, 4 and 4-1/2 inch  
**CASE MATERIAL:** Brass or stainless steel (dry or liquid filled)  
**CONNECTION:** Bottom connection; back connection; lower back connection  
**OPTIONAL FILL FLUIDS:** Glycerine, Glycerine-H<sub>2</sub>O and Silicone  
**MOUNTING OPTIONS:** Front or rear flange, bezel & U-clamp  
**RANGES:** -40 °F/C to 60 °F/C through 50 °F/C to 400 °F/C  
**CAPILLARY LENGTH & MATERIAL:** Copper & stainless steel; 5 foot to 40 foot  
**BULB MATERIAL & DIMENSIONS:** Copper or stainless steel; 2-5/8 x 3/8 inch through 7 x 12 inch



## REMOTE THERMOMETERS

**NOSHOK VAPOR ACTUATED REMOTE THERMOMETERS** operate using a temperature actuated liquid in the sensing element and a highly accurate, high quality pressure gauge to indicate media temperature. As the media temperature increases the capillary fill fluid vaporizes, causing an increase of pressure within the bourdon tube, and activates the movement and pointer for proper indication. Dial scale graduations are non linear, therefore, the highest degree of accuracy and readability is found in the upper half of the scale.

**WARRANTY:** One Year†

## SPECIFICATIONS

**MATERIALS:** Brass, 304 stainless steel or 316 stainless steel  
**INSERTION:** 1-5/8 inch to 22 inch  
**BORE DEPTH:** 2-1/2 inch to 24 inch  
**PROCESS CONNECTION:** 3/4 inch – STD; Others available upon request



## THERMOWELLS

**NOSHOK THERMOWELLS** are recommended whenever the process being measured may be under pressure, is corrosive, abrasive or may be at a high velocity. They are also recommended as protection to the operator. The correct thermowell will reduce the possibility of damage to the temperature instrument and allows an instrument to be removed and replaced without shutting down and possibly draining the process. Standard thermowells are supplied with 1/2 inch NPSM instrument connection. The female thread will accept the 1/2 inch NPT male thread without galling or seizing.

**WARRANTY:** One Year†

# HYDRAULIC LOAD CELLS

## SPECIFICATIONS

**NOMINAL DIAMETER:** 6cm<sup>2</sup>  
**LOAD CELL HOUSING MATERIAL:** Stainless steel  
**PISTON:** Stainless steel – STD; plastic – Optional  
**CONNECTING LINE:** 50mm adapter – STD; others available  
**RANGES:** From 150 lbs-force through 7,000 lbs-force

### MEASURING INSTRUMENT

**PRESSURE GAUGE:** 2-1/2 inch 300 Series, one piece die cast brass case; dry or liquid filled  
**TRANSDUCER:** 100, 200 or 615 Series transducer  
**OUTPUT SIGNALS:** 4 mA to 20 mA, 2-wire: 0 Vdc to 5 Vdc, 0 Vdc to 10 Vdc, 1 Vdc to 5 Vdc, 1 Vdc to 6 Vdc & 1 Vdc to 11 Vdc, 3-wire  
**ACCURACY:** ±0.125% Full Scale (B.F.S.L) to ±1.5% Full Scale  
**OPERATING TEMP:** 14 °F to 122 °F (-10 °C to 50 °C)  
**AMBIENT TEMP:** -4 °F to 140 °F (-20 °C to 60 °C)



## 1000 SERIES

**NOSHOK HYDRAULIC LOAD CELLS** are engineered with a compact flat body design for use within control systems of spot welding machines, robots, printing machines and other compression force measurement applications. The stainless steel housing and piston provide for exceptional corrosion resistance and extended service life. Accuracy levels range from ±0.125% full scale (B.F.S.L) to ±1.5% full scale depending on the measuring instrument.

**WARRANTY:** One Year†; Three Year† on liquid filled gauges & transducers

## SPECIFICATIONS

**NOMINAL DIAMETER:** 20cm<sup>2</sup>  
**LOAD CELL HOUSING MATERIAL:** Stainless steel  
**PISTON:** Stainless steel  
**CONNECTING LINE:** Direct connection – STD; flexible tubing, capillary restrictor  
**RANGES:** From 300 lbs-force through 22,000 lbs-force

### MEASURING INSTRUMENT

**PRESSURE GAUGE:** 2-1/2 inch 300 Series, one piece die cast brass case; dry or liquid filled; 4 inch 901 Series stainless steel case; dry or liquid filled  
**TRANSDUCER:** 100, 200 or 615 Series transducer  
**OUTPUT SIGNALS:** 4 mA to 20 mA, 2-wire: 0 Vdc to 5 Vdc, 0 Vdc to 10 Vdc, 1 Vdc to 5 Vdc, 1 Vdc to 6 Vdc & 1 Vdc to 11 Vdc, 3-wire  
**ACCURACY:** ±0.5% Full Scale (B.F.S.L) to ±0.125% Full Scale  
**OPERATING TEMP:** 14 °F to 122 °F (-10 °C to 50 °C)  
**AMBIENT TEMP:** -4 °F to 140 °F (-20 °C to 60 °C)



## 2000 SERIES

**NOSHOK HYDRAULIC LOAD CELLS** are designed for measuring axial loads and bearing forces in turning and drilling machines, extruders, and other compression or tension force applications. The self adapting piston and housing are constructed of high grade, corrosion resistant stainless steel and are available in standard or ring form. A high quality, highly accurate NOSHOK pressure gauge or transducer is attached for measurement indication.

**WARRANTY:** One Year†; Three Year† on liquid filled gauges & transducers

† For further warranty information please consult your specific product catalogs.

## SPECIFICATIONS

**NOMINAL DIAMETER:** 80cm<sup>2</sup>

**LOAD CELL HOUSING MATERIAL:** Stainless steel

**PISTON:** Stainless steel

**CONNECTING LINE:** Direct connection – STD; flexible tubing, capillary restrictor

**RANGES:** From 25,000 lbs-force through 70,000 lbs-force

### MEASURING INSTRUMENT

**PRESSURE GAUGE:** 2-1/2 inch 300 Series, one piece die cast brass case; dry or liquid filled; 4 inch 901 Series stainless steel case; dry or liquid filled

**TRANSDUCER:** 100, 200 or 615 Series transducer

**OUTPUT SIGNALS:** 4 mA to 20 mA, 2-wire: 0 Vdc to 5 Vdc, 0 Vdc to 10 Vdc, 1 Vdc to 5 Vdc, 1 Vdc to 6 Vdc & 1 Vdc to 11 Vdc, 3-wire

**ACCURACY:** ±0.50% Full Scale (B.F.S.L) to ±0.125% Full Scale

**OPERATING TEMP:** 14 °F to 122 °F (-10 °C to 50 °C)

**AMBIENT TEMP:** -4 °F to 140 °F (-20 °C to 60 °C)



## 3000 SERIES

**NOSHOK HYDRAULIC LOAD CELLS** are constructed from a high grade, corrosion resistant stainless steel and joined with a high quality NOSHOK pressure gauge or transducer to measure axial loads and bearing forces in turning and drilling machines, extruders and other compression force measurement applications. Accuracy levels range from ±0.25% full scale (B.F.S.L) to ±1.5% full scale depending on the measuring instrument with measuring ranges from 25,000 lbs-force through 70,000 lbs-force.

**WARRANTY:** One Year†; Three Year† on liquid filled gauges & transducers

## SPECIFICATIONS

**NOMINAL DIAMETER:** 100cm<sup>2</sup>

**LOAD CELL HOUSING MATERIAL:** Galvanized and chrome plated steel

**PISTON:** Stainless steel

**CONNECTING LINE:** Rigid tubing; flexible tubing, capillary restrictor

**RANGES:** From 230 lbs-force through 500,000 lbs-force

### MEASURING INSTRUMENT

**PRESSURE GAUGE:** 4 inch 901 Series stainless steel case; dry or liquid filled; 6 inch 400/500 Series all stainless steel gauge

**TRANSDUCER:** 100, 200 or 615 Series transducer

**OUTPUT SIGNALS:** 4 mA to 20 mA, 2-wire: 0 Vdc to 5 Vdc, 0 Vdc to 10 Vdc, 1 Vdc to 5 Vdc, 1 Vdc to 6 Vdc & 1 Vdc to 11 Vdc, 3-wire

**ACCURACY:** ±0.50% Full Scale (B.F.S.L) to ±0.125% Full Scale

**OPERATING TEMP:** 14 °F to 122 °F (-10 °C to 50 °C)

**AMBIENT TEMP:** -4 °F to 140 °F (-20 °C to 60 °C)



## 4000 SERIES

**NOSHOK HYDRAULIC LOAD CELLS** are designed for level measurement, rope and belt tension and torque measurement, bearing support forces on lifting equipment and other compression force measurement applications. The cell housing is built from a durable galvanized and chrome plated steel while the piston is constructed from a high grade stainless steel for exceptional corrosion resistance. Measuring ranges vary from 230 lbs-force through 500,000 lbs-force with accuracy levels ranging from ±0.25% full scale (B.F.S.L) to ±1% full scale depending on the measuring instrument.

**WARRANTY:** One Year†; Three Year† on liquid filled gauges & transducers

## SPECIFICATIONS

**NOMINAL DIAMETER:** 160cm<sup>2</sup>

**LOAD CELL HOUSING MATERIAL:** Stainless steel

**PISTON:** Stainless steel

**CONNECTING LINE:** Rigid tubing; flexible tubing, capillary restrictor

**RANGES:** From 900 lbs-force through 630,000 lbs-force

### MEASURING INSTRUMENT

**PRESSURE GAUGE:** 4 inch 901 Series stainless steel case; dry or liquid filled; 6 inch 400/500 Series all stainless steel gauge

**TRANSDUCER:** 100, 200 or 615 Series transducer

**OUTPUT SIGNALS:** 4 mA to 20 mA, 2-wire: 0 Vdc to 5 Vdc, 0 Vdc to 10 Vdc, 1 Vdc to 5 Vdc, 1 Vdc to 6 Vdc & 1 Vdc to 11 Vdc, 3-wire

**ACCURACY:** ±0.50% Full Scale (B.F.S.L) to ±0.125% Full Scale

**OPERATING TEMP:** 14 °F to 122 °F (-10 °C to 50 °C)

**AMBIENT TEMP:** -4 °F to 140 °F (-20 °C to 60 °C)



## 5000 SERIES

**NOSHOK HYDRAULIC LOAD CELLS** are designed in a distinctive ring shaped form for compression and tension force measurement in injection molding machine screws, tailstock spindles, propeller shafts, rope and torque measurement applications and more. The high grade stainless steel housing and piston provide exceptional corrosion resistance and durability. Measuring ranges vary from 900 lbs-force through 630,000 lbs-force with accuracy levels ranging from ±0.25% full scale (B.F.S.L) to ±1% full scale depending on the measuring instrument.

**WARRANTY:** One Year†; Three Year† on liquid filled gauges & transducers

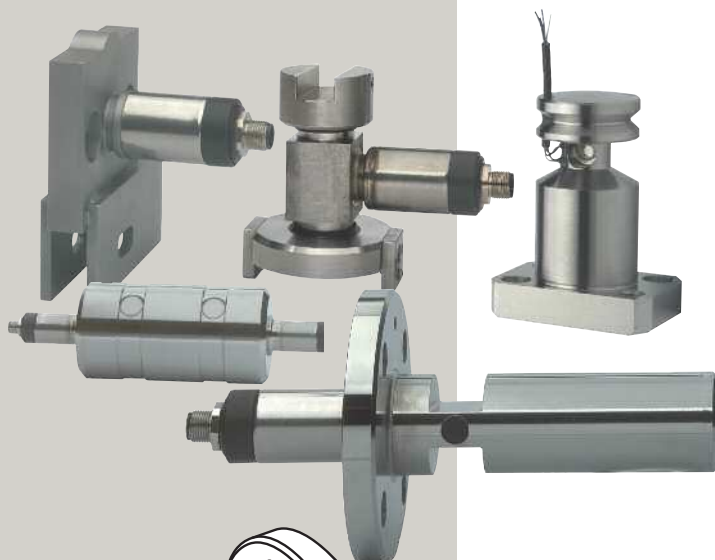

**THE NOSHOK-TECSIS CUSTOM FORCE SENSOR** is a break through in force measurement. Utilizing proven thin film sensor technology combined with an advanced automated production process we create a highly adaptive force transmitter that is suitable for industrial use. This development process gives the customer complete freedom in creating a high quality, highly accurate force sensor that is custom designed and engineered to meet their specific application needs.

NOSHOK-TECSIS Custom Force Sensors provide the OEM and end user alike with unsurpassed flexibility to achieve a previously unattainable solution because of nonconforming standard designs and high accuracy requirements. NOSHOK achieves this solution in a way that is performance and reliability enhancing while remaining cost effective.

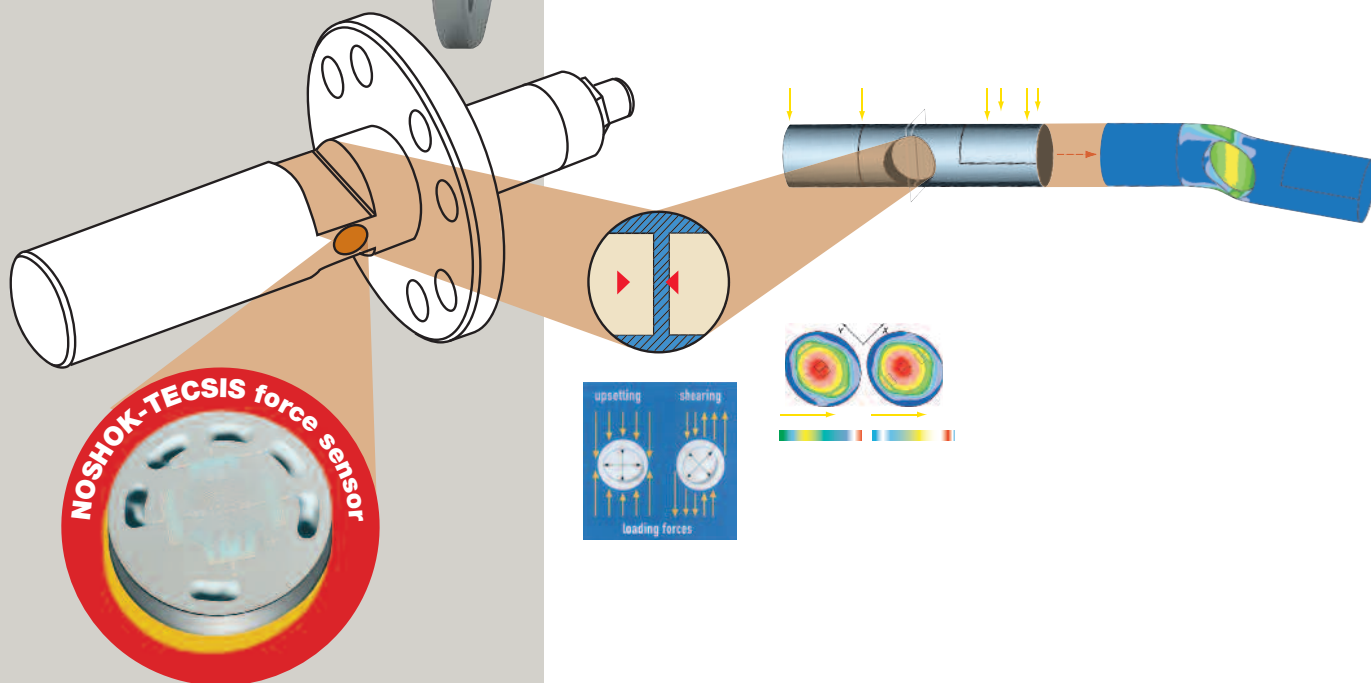

## SPECIFICATIONS

**OUTPUT SIGNAL:** 4 mA to 20 mA, 2-wire, 0 Vdc to 5 Vdc, 3-wire, 0 Vdc to 10 Vdc, 3-wire  
**NOMINAL RANGES:** 1 kN (225lbs-force) to 500 kN (112,500/lbs-force) Standard. Others available – please consult factory  
**LIMIT FORCE:** 150%  $F_{nom}$   
**FRACTURE FORCE:** >300%  $F_{nom}$   
**ACCURACY:** < 1% Full Scale  
**HYSTERESIS:** < 0.5% Full Scale  
**POWER SUPPLY:** 10 Vdc to 30 Vdc; 14 Vdc to 30 Vdc for 0 Vdc to 10 Vdc output  
**HOUSING MATERIAL:** 316 stainless steel  
**RESPONSE TIME:**  $\leq$  0.5s (between 10% to 90% Full Scale)  
**ENVIRONMENTAL RATING:** IP 67, NEMA 4X to EN 60529/IEC 529  
**ELECTRICAL PROTECTION:** Reverse polarity, over-voltage and short circuit protection  
**VIBRATION:** 20g's per IEC 68-2  
**ELECTRICAL CONNECTION:** M12 X 1, 4-pin Standard;

Others available – please consult factory

## FEATURES

- Custom designed and built to the exact application specifications requiring less space for mounting and installation
- The NOSHOK-TECSIS proven thin film sensor is LASER WELDED to the deformation body for superior strength and performance
- Extremely accurate, with the help of Finite Element Method Analysis, the sensor is able to reach accuracies from 0.2% to 1% full scale
- Available in a variety of standard current and voltage output signals, with others available upon request
- High quality product produced in an automated system with cost effective pricing
- Deformation body is constructed from a high grade, high quality stainless steel that provides exceptional durability and contributes to extended service life



## NOSHOK CHAIN HOIST TEST KIT

FOR FRICTION CLUTCH TESTING ON CHAIN HOISTS

The NOSHOK Chain Hoist Test Kit (CHTK) for overload cutoff is a precise, durable and dependable tester for slip couplings on chain hoists. The CHTK provides a wide range of measurement, with high accuracy, low weight and ease of use.

To perform the test, the force transducer is inserted into the chain, travels upwards with it against the base of the chain hoist and thereby blocks the chain. The display unit allows you to read the load at which the friction clutch stalls.

The CHTK consists of a force transducer with integrated handle and a display unit. Two chain adapters and three centering sleeves are also included in the kit, to ensure the CHTK can be used for most types of chain hoists in the specified load range. The large illuminated graphic display makes it very easy for the user to read the measured values. Optionally, 99 different data sets can be stored and transferred via an infrared interface to a PC. The CHTK's special feature is the single sensor concept for the entire load range.



## NOSHOK WELD FORCE TEST KIT

FOR MEASURING ELECTRODE FORCE ON SPOT WELDING EQUIPMENT

NOSHOK's Weld Force Test Kit (WFTK) is designed to easily and accurately check electrode force in spot welding equipment. The WFTK consists of a force transducer, a handheld display unit, plastic carrying case, charger, 2-meter signal cable and Manufacturer's Test Certificate. The WFTK weighs only 13 lbs, and features a Max/Min Value Memory, a large illuminated display, and electrode diameters of 14–20mm.

To check the force acting on the electrodes, the force transducer is held between the electrodes. The concave surfaces center the force transducer. When the welding electrodes come together, the magnitude of the applied force can be read on the display unit. The force transducer is insensitive to transverse forces and torques. It has a measuring range of 0–10kN. The output signal is connected to the handheld display unit via a cable. This display unit carries the voltage supply for the transducer. Alternatively, the supply can be taken from a PLC. The sensor, which is laser welded, has all the advantages of the conventional bonded foil strain gauges, but without having their substantial disadvantages (temperature drifts due to the glue and creeping).

## SPECIFICATIONS

**OUTPUT SIGNAL:** 1-2 mV/V 4-wire, 4 mA to 20 mA 2-wire, 0 Vdc to 10 Vdc 3-wire, CANopen-fieldbus, others available on request

**MEASURING RANGES:** 0 kN to 5 kN through 0 kN to 200 kN

**ACCURACY:** ±1.0% full scale to ±0.5% full scale

**HOUSING MATERIAL:** 316 stainless steel

**ENVIRONMENTAL PROTECTION:**

NEMA 4X, IP67 per EN 60529/IEC 529

**OPERATING TEMPERATURE:** -40 °F to 176 °F (-40 °C to 80 °C)

**ELECTRICAL PROTECTION:** Reverse polarity, overvoltage and short circuit protection



## 5301/5308 SERIES

**NOSHOK LOAD PINS** utilize our proven thin film sensor technology laser welded directly to the measuring instrument. This technology gives us the ability to offer accuracies up to ±0.5% and minimize the disadvantages seen in the bonded foil versions (temperature drifts and long term stability). They are available in many different sizes and shapes for the direct replacement of existing bolts where a force measurement may need to be taken. Various output signals are available to integrate with almost any electrical system. Common applications for load pins are force measurement on roller bearings, industrial weighing, measurement of cable tension on hoists and overload protection on cranes.

## SPECIFICATIONS

**OUTPUT SIGNAL:** 1-2 mV/V 4-wire, 4 mA to 20 mA 2-wire, 0 Vdc to 10 Vdc 3-wire, others available on request  
**MEASURING RANGES:** 0 N to 5 N through 0 kN to 5,000 kN  
**ACCURACY:**  $\pm 2.0\%$  full scale to  $\pm 0.04\%$  full scale  
**HOUSING MATERIAL:** 316 stainless steel or aluminum, dependent on version  
**ENVIRONMENTAL PROTECTION:** NEMA 4X, IP67 per EN 60529/IEC 529  
**OPERATING TEMPERATURE:**  $-40^\circ\text{F}$  to  $176^\circ\text{F}$  ( $-40^\circ\text{C}$  to  $80^\circ\text{C}$ )  
**ELECTRICAL PROTECTION:** Reverse polarity, overvoltage and short circuit protection



## 3540 SERIES

**NOSHOK TENSION AND COMPRESSION FORCE TRANSDUCERS** are available in many different sizes and shapes to fit almost any application. They are available in measuring ranges as small as 0 N to 5 N and as high as 0 kN to 5,000 kN with accuracies from  $\pm 2\%$  to  $\pm 0.04\%$  depending on the version. Several outputs are available in both amplified and unamplified to interface with most electrical systems. Many versions are manufactured from stainless steel which makes them suitable for installation in harsh environments. Applications for use of this product include cable or rod tension, weight measurement, overload protection, clamping force and fill level measurement.

## SPECIFICATIONS

**ACCURACY:** 0.2%  
**OUTPUT SIGNAL:** 4 mA to 20 mA; 2-wire system, and 0 Vdc to 10 Vdc; 3-wire system  
**MEASURING RANGES:** Tension/compression forces from (0.75 kN) 2 kN to 50 kN

## FEATURES

- Thin film implants
- Integrated amplifier
- Measuring range selection with manual programming unit EPE01 (optional)
- Integrated overload protection for tension & compression direction (optional)
- Small temperature drift
- High long term stability
- High shock and vibration resistance
- For dynamic or static measurements
- Good repeatability & easy assembly

## APPLICATIONS

- Hoisting gear
- Engagement forces in machinery
- Automated manufacturing
- Construction of plant and machinery



## 2351 SERIES

**NOSHOK S-TYPE TENSION AND COMPRESSION FORCE TYPE TRANSDUCERS** have a conventional design, featuring internal threads which allow force to be easily introduced via suitable swivel heads. The factory-internal calibration is performed in tension and compression directions: 4 mA to 20 mA and 0 Vdc to 10 Vdc. The zero signal is therefore around 12 mA and 5V, respectively. Calibrations in the tension or compression direction only are available at no extra charge. The S-type has a connector plug on the broad side of the body. With an angled cable socket, the cable runs parallel to the direction of force. This allows space-saving and protected installation on plant and machinery.

A variant of the S-type with integrated overload protection and a selectable measuring range is available especially for applications in measurement engineering. With the aid of the EPE01 programming unit, any of three different measuring ranges (100%, 50% and 30%) can be selected without having to remove the force transducer. Calibration characteristics stored in the digital amplifier allow an accuracy of 0.2% of FSD for each measuring range. The overload protection is rated for 250% of the maximum nominal load.

## SPECIFICATIONS

**MATERIAL:** Zinc nickel-plated steel, electropolished stainless steel, 360 brass  
**CONNECTIONS:** 1/8 inch NPT, 1/4 inch NPT, 7/16 inch-20 UNF -2B M-M, M-F, F-F in-line and angled configurations  
**ORIFICE SIZE:** 0.172 inch, maximum Cv of 0.42  
**OPTIONS:** Panel mount options, o-ring materials, handle options

All NOSHOK valves are 100% helium leak tested to  $1 \times 10^{-4}$  ml/s for guaranteed performance and reliability.

All NOSHOK Valve Products conform to MSS SP-1999 (R 2005) Instrument Valve Standards, and valves supplied with packings conform to MSS SP-132-2004 Compression Packing Systems for Instrument Valves also.



## HARD SEAT & SOFT TIP

### 100/150 SERIES

**NOSHOK MINI VALVES** are small in size but deliver maximum strength and durability. Available in electroless nickel-plated steel, electropolished stainless steel and natural brass, these rugged Mini Viton® Valves are equipped with an O-ring and Teflon® back-up ring below the stem threads to protect against corrosion and galling. Stem threads are rolled for greater strength and ease of operation. 100 Series feature a metal-to-metal hard seat with a bubble tight seal, and have a maximum pressure of 10,000 psi for stainless steel and steel models, and 6,000 psi for brass. 150 Series valves feature a patented Delrin® non-rotating soft tip stem. They have a max pressure of 6,000 psi for stainless steel and steel models, and 3,000 psi for brass.

**WARRANTY:** Three Years†

## SPECIFICATIONS

**MATERIAL:** Zinc nickel-plated steel, electropolished stainless steel  
**CONNECTIONS:** 1/2 inch NPT, to 3/4 inch NPT, M-F, straight through porting for bi-directional, high capacity flow  
**ORIFICE SIZE:** 0.187 inch, maximum Cv for 200 Series: 0.44; maximum Cv for 300 Series: 0.64  
**STEM PACKING & TYPE:** All 316 stainless steel stems with Viton® o-ring and Teflon® back up ring below the threads

All NOSHOK valves are 100% helium leak tested to  $1 \times 10^{-4}$  ml/s for guaranteed performance and reliability.

All NOSHOK Valve Products conform to MSS SP-1999 (R 2005) Instrument Valve Standards, and valves supplied with packings conform to MSS SP-132-2004 Compression Packing Systems for Instrument Valves also.



## HARD & SOFT SEAT

### 200/300 SERIES

**NOSHOK MULTIPORT VALVES** reduce the number of gauge and other instrument connections to permanent piping installations, therefore decreasing possible leak points (paths). Optional bleed plugs further allow pressure to be bled off without disturbing the permanent piping installation. The metal-to-metal hard seat design has a maximum pressure rating to 10,000 psi @ 200 °F. The soft seat design, with the replaceable Delrin® seat, is pressure rated to 6,000 psi @ 200 °F.

**WARRANTY:** Three Years†

## SPECIFICATIONS

**400 SERIES:**  
**MATERIAL:** Zinc nickel-plated steel, electropolished stainless steel  
**CONNECTIONS:** 1/4, 3/8, 1/2, 3/4, 7/16 inch-20 UNF -2B, 1 & 1-1/2 inch 1/4 NPT, M-F, F-F, in-line and angled configuration  
**ORIFICE SIZE:** Models 402-404: 0.187 inch with max. Cv of 0.44; Models 406-412: 0.438 inch with Max. Cv of 2.7

**500 SERIES:**  
**MATERIAL:** Zinc nickel-plated steel, electropolished stainless steel  
**CONNECTIONS:** 1/4 inch, 3/8 inch & 1/2 inch NPT; M-F, F-F configurations available  
**ORIFICE SIZE:** Models 502-504: 0.187 inch with max. Cv of 0.76 Models 506-512: 0.438 inch with max. Cv of 2.7

All NOSHOK valves are 100% helium leak tested to  $1 \times 10^{-4}$  ml/s for guaranteed performance and reliability.

All NOSHOK Valve Products conform to MSS SP-1999 (R 2005) Instrument Valve Standards, and valves supplied with packings conform to MSS SP-132-2004 Compression Packing Systems for Instrument Valves also.



## HARD SEAT & SOFT SEAT

**NOSHOK HARD & SOFT SEAT VALVES** are the work horses of the industry. The 400 Series' metal-to-metal hard seat design is pressure rated to 10,000 psi @ 200 °F and helium leak tested to  $1 \times 10^{-4}$  ml/s for guaranteed performance and reliability. The 500 Series valves are fitted with a precision molded, replaceable Delrin® soft seat that is the key to the bubble tight seal. They have a maximum pressure rating of 6,000 psi @ 200 °F with straight through porting for bi-directional, high capacity flow and easy roddable cleaning.

The all 316 stainless steel blow out proof stem provides greater service life and provides a secondary stem seal in the full open position. On the 400 Series, the stem and the one piece bonnet threads are rolled for greater strength and ease of operation. Both the 400 and 500 Series feature stem seal below the threads to protect against corrosion and galling.

**WARRANTY:** Three Years†



## SPECIFICATIONS

**MATERIAL:** Zinc nickel-plated steel, electropolished stainless steel

**CONNECTIONS:** 1/4 inch NPT & 1/2 inch NPT; M-F, F-F configurations available

**ORIFICE SIZE:** 600 Series: 0.187 inch with max. Cv of 0.44; 700 Series: 0.187 inch with max. Cv of 0.76

All NOSHOK valves are 100% Helium leak tested to  $1 \times 10^{-4}$  ml/s for guaranteed performance and reliability.

All NOSHOK Valve Products conform to MSS SP-1999 (R 2005) Instrument Valve Standards, and valves supplied with packings conform to MSS SP-132-2004 Compression Packing Systems for Instrument Valves also.



### HARD & SOFT SEAT

## 600/700 SERIES

**NOSHOK BLOCK & BLEED VALVES** allow pressure to be bled off without disturbing the permanent piping installation thereby enabling the user to quickly and easily remove and/or replace instruments. The metal-to-metal hard seat design is pressure rated to 10,000 psi @ 200 °F and the soft seat design, with a replaceable Delrin® seat, is rated to 6,000 psi @ 200 °F. The all 316 stainless steel blow out proof stem provides greater service life and a secondary stem seal in the full open position. Stem seals, with the Viton® O-ring and Teflon® back up ring, is below the threads and protects against galling and corrosion.

**WARRANTY:** Three Years†

## SPECIFICATIONS

**MATERIAL:** Zinc nickel-plated steel, electropolished

316 stainless steel, 360 brass

**CONNECTIONS:** 1/2 inch NPT; 1/4 inch NPT

**ORIFICE SIZE:** .090 inch bleed hole

**STEM SEAL:** Viton® o-ring and Teflon® back up ring standard, Teflon® or Grafoil® packing optional

All NOSHOK valves are 100% helium leak tested to  $1 \times 10^{-4}$  ml/s for guaranteed performance and reliability.

All NOSHOK Valve Products conform to MSS SP-1999 (R 2005) Instrument Valve Standards, and valves supplied with packings conform to MSS SP-132-2004 Compression Packing Systems for Instrument Valves also.



### HARD SEAT & SOFT TIP

## 800/850 SERIES

**NOSHOK BLEED VALVES** provide a convenient means to relieve process pressures trapped between a shut off valve and the instrument. Bleed valves use the same bonnet assemblies of the 100/150 series mini valves with an integrated single threaded body for insertion in a vent port. The bleed valve provides shutoff to a small bleed hole located on the side the hex which vents to atmosphere. They are available in electroless nickel plated steel, electropolished stainless steel and brass. All bleed valves are equipped with a Viton® O-ring and Teflon® back up ring below the stem threads to protect against corrosion and galling. Stem threads are rolled for greater strength and ease of operation. Maximum pressure rating of 10,000 psi for steel & stainless steel models and 6,000 psi for brass models.

**WARRANTY:** Three Years†

## SPECIFICATIONS

**MATERIAL:** Zinc nickel-plated steel, electropolished

316 stainless steel

**CONNECTIONS:** 1/2 inch NPT; M-F, F-F configurations available

**ORIFICE SIZE:** 2070 Series: 0.187 inch with Cv of 0.44;

2170 Series: 0.187 inch with Cv of 0.76

**STEM SEAL:** Viton® o-ring and Teflon® back up ring standard, Teflon® or Grafoil® packing optional

**LENGTH:** 4 inch standard and 5-3/8 inch extended length available.

All NOSHOK valves are 100% Helium leak tested to  $1 \times 10^{-4}$  ml/s for guaranteed performance and reliability.

All NOSHOK Valve Products conform to MSS SP-1999 (R 2005) Instrument Valve Standards, and valves supplied with packings conform to MSS SP-132-2004 Compression Packing Systems for Instrument Valves also.



### HARD & SOFT SEAT

## 2070/2170 SERIES

**NOSHOK 2-VALVE BLOCK & BLEED VALVES** combine isolating and venting in a single valve, eliminating the need for tubing and fittings. The block valve isolates the downstream process fluids, and the bleed valve exhausts upstream fluids enabling instruments to be removed without disturbing the permanent piping installation. The 1/4 inch NPT vent plug may be removed and replaced with exhaust piping to direct the fluids to a safe location. The metal-to-metal hard seat design is pressure rated to 10,000 psi @ 200 °F and the soft seat design, with a replaceable Delrin® seat, is rated to 6,000 psi @ 200 °F. The all 316 stainless steel blow out proof stem provides greater service life and a secondary stem seal in the full open position. The standard stem seal is below the threads and protects against galling and corrosion.

**WARRANTY:** Three Years†

# 2-VALVE STATIC PRESSURE MANIFOLDS

## HARD & SOFT SEAT

### SPECIFICATIONS

**MATERIAL:** Zinc nickel-plated steel, electropolished  
316 stainless steel

**CONNECTIONS:** 1/2 inch NPT standard, 1/4 inch NPT optional, left venting is optional, NPT-Flange, Flange-Flange available

**ORIFICE SIZE:** 2000 Series: 0.187 inch with Cv of 0.44 inch; 2100 Series: 0.187 inch with Cv of 0.76

**STEM SEAL:** Viton® O-ring and Teflon® back up ring standard, Teflon® or Grafoil® packing optional

All NOSHOK valves are 100% Helium leak tested to  $1 \times 10^{-4}$  ml/s for guaranteed performance and reliability.

All NOSHOK Valve Products conform to MSS SP-1999 (R 2005) Instrument Valve Standards, and valves supplied with packings conform to MSS SP-132-2004 Compression Packing Systems for Instrument Valves also.



## 2000/2100 SERIES

**NOSHOK STATIC PRESSURE BLOCK & BLEED MANIFOLDS** combine isolating and venting in a single manifold eliminating the need for tubing and fittings. The block valve isolates the downstream process fluids and the bleed valve exhausts upstream fluids enabling static pressure transmitters, switches or gauges to be removed without disturbing the permanent piping installation. The block valve is located on the side and the bleed valve is located on top in a 90° orientation. Venting is to the right. The metal-to-metal hard seat design is pressure rated to 10,000 psi @ 200 °F and the replaceable Delrin® soft seat design is rated to 6,000 psi @ 200 °F. The all 316 stainless steel blow out proof stem provides greater service life and a secondary stem seal in the full open position. Stem seal, with the Viton® O-ring and Teflon® back up ring, is below the threads and protects against galling and corrosion.

**WARRANTY:** Three Years†

## HARD & SOFT SEAT

### SPECIFICATIONS

**MATERIAL:** Zinc nickel-plated steel, electropolished  
316 stainless steel

**CONNECTIONS:** 200002/210002 Series: Flange-Flange, 1/4 inch NPT vent  
200402/210402 Series: 1/2 inch NPT-Flange, 1/4 inch NPT vent

**ORIFICE SIZE:** 200402 Series: 0.187 inch with Cv of 0.44;  
210402 Series: 0.187 inch with Cv of 0.76

**STEM SEAL:** Viton® O-ring and Teflon® back up ring standard, Teflon® or Grafoil® packing optional

All NOSHOK valves are 100% helium leak tested to  $1 \times 10^{-4}$  ml/s for guaranteed performance and reliability.

All NOSHOK Valve Products conform to MSS SP-1999 (R 2005) Instrument Valve Standards, and valves supplied with packings conform to MSS SP-132-2004 Compression Packing Systems for Instrument Valves also.

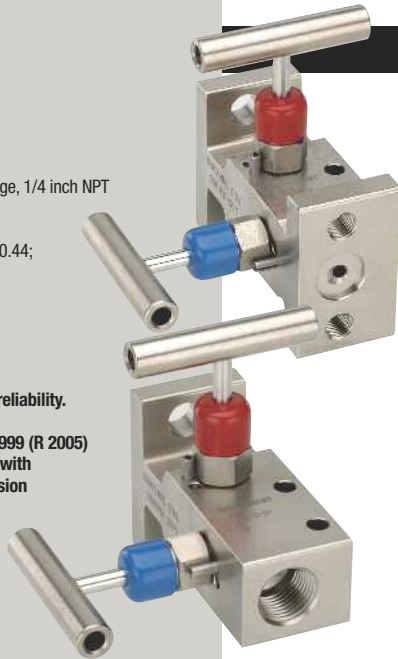

## 200002/210002 SERIES 200402/210402 SERIES

**NOSHOK STATIC PRESSURE NARROW BLOCK & BLEED MANIFOLDS** combine isolating and venting in a single manifold eliminating the need for tubing and fittings. The block valve isolates the downstream process fluids and the bleed valve exhausts upstream fluids enabling static pressure transmitters, switches or gauges to be removed without disturbing the permanent piping installation. The block valve is located on the side and the bleed valve is located on top in a 90° orientation. Venting is to the right. The metal-to-metal hard seat design is pressure rated to 10,000 psi @ 200 °F and the replaceable Delrin® soft seat design is rated to 6,000 psi @ 200 °F. The all 316 stainless steel blow out proof stem provides greater service life and a secondary stem seal in the full open position. Stem seal, with the Viton® O-ring and Teflon® back up ring, is below the threads and protects against galling and corrosion.

**WARRANTY:** Three Years†

## HARD SEAT & SOFT TIP -.141 INCH ORIFICE

### SPECIFICATIONS

**MATERIAL:** Zinc nickel-plated steel, electropolished  
316 stainless steel

**CONNECTIONS:** 1/4 inch NPT standard, 1/8 inch NPT optional, right venting optional

**ORIFICE SIZE:** 0.141 inch with Cv of 0.38

**STEM SEAL:** Viton® O-ring and Teflon® back up ring standard, Teflon® or Grafoil® packing optional

All NOSHOK valves are 100% helium leak tested to  $1 \times 10^{-4}$  ml/s for guaranteed performance and reliability.

All NOSHOK Valve Products conform to MSS SP-1999 (R 2005) Instrument Valve Standards, and valves supplied with packings conform to MSS SP-132-2004 Compression Packing Systems for Instrument Valves also.



## 2602/2702 SERIES

**NOSHOK STATIC PRESSURE MINI BLOCK & BLEED MANIFOLDS** combine isolating and venting in a single manifold eliminating the need for tubing and fittings. The block valve isolates the downstream process fluids and the bleed valve exhausts upstream fluids enabling static pressure transmitters, switches or gauges to be removed without disturbing the permanent piping installation. The valves are located on the top to fit into compact spaces and two holes are provided for mounting. Venting is to the left. The metal-to-metal hard seat design is pressure rated to 10,000 psi @ 200 °F and the patented soft Delrin® tip design is rated to 6,000 psi @ 200 °F. The all 316 stainless steel blow out proof stem provides greater service life and a secondary stem seal in the full open position. Stem seal, with the Viton® O-ring and Teflon® back up ring, is below the threads and protects against galling and corrosion.

**WARRANTY:** Three Years†

# 2-VALVE STATIC PRESSURE & LIQUID LEVEL MANIFOLDS

HARD SEAT & SOFT TIP -.156 INCH ORIFICE

## SPECIFICATIONS

**MATERIAL:** Zinc nickel-plated steel, electropolished  
316 stainless steel

**CONNECTIONS:** 2603/2703 series 3/8 inch NPT,  
2604/2704 series 1/2 inch NPT, right venting optional.

**ORIFICE SIZE:** 0.156 inch

**STEM PACKING & TYPE:** Viton® O-ring and Teflon® back up  
ring standard, Teflon® or Grafoil® packing optional

All NOSHOK valves are 100% Helium leak tested  
to  $1 \times 10^{-4}$  ml/s for guaranteed performance  
and reliability.

All NOSHOK Valve Products conform to  
MSS SP-1999 (R 2005) Instrument Valve Standards,  
and valves supplied with packings conform to  
MSS SP-132-2004 Compression Packing Systems  
for Instrument Valves also.



## 2603/2703 SERIES 2604/2704 SERIES

**NOSHOK STATIC PRESSURE MINI BLOCK & BLEED MANIFOLDS** combine isolating and venting in a single manifold eliminating the need for tubing and fittings. The block valve isolates the downstream process fluids and the bleed valve exhausts upstream fluids enabling static pressure transmitters, switches or gauges to be removed without disturbing the permanent piping installation. The block valve is located on the side and the bleed valve is located on top in a 90° orientation. Venting is to the left. The metal-to-metal hard seat design is pressure rated to 10,000 psi @ 200 °F and the patented soft Delrin® tip design is rated to 6,000 psi @ 200 °F. The all 316 stainless steel blow out proof stem provides greater service life and a secondary stem seal in the full open position. Stem seal, with the Viton® O-ring and Teflon® back up ring, is below the threads and protects against galling and corrosion.

WARRANTY: Three Years†

## SPECIFICATIONS

**MATERIAL:** Zinc nickel-plated steel, electropolished  
316 stainless steel

**CONNECTIONS:** Flange – Flange, 1/2 inch NPT - Flange

**ORIFICE SIZE:** 0.187 inch

**STEM PACKING & TYPE:** All 316 stainless steel stems with  
Viton® O-ring and Teflon® back up ring below the threads

All NOSHOK valves are 100% helium leak tested  
to  $1 \times 10^{-4}$  ml/s for guaranteed performance  
and reliability.

All NOSHOK Valve Products conform to  
MSS SP-1999 (R 2005) Instrument  
Valve Standards, and valves supplied  
with packings conform to MSS SP-132-2004  
Compression Packing Systems for Instrument Valves also.



HARD & SOFT SEAT

## 2020/2120 SERIES

**NOSHOK LIQUID LEVEL MANIFOLDS** are designed for use with differential pressure transmitters in liquid level applications. These valves are available in either single flange or double flange connection for direct installation. The metal-to-metal hard seat valve is pressure rated to 10,000 psi @ 200 °F with a flow coefficient factor of 0.44. The soft seat design features a replaceable Delrin® seat with straight through porting for bi-directional flow and easy roddable cleaning. Maximum pressure rating on the soft seat is 6,000 psi @ 200 °F with a flow coefficient factor of 0.76.

WARRANTY: Three Years†

# 3-VALVE DIFFERENTIAL PRESSURE MANIFOLDS

HARD & SOFT SEAT

## SPECIFICATIONS

**MATERIAL:** Zinc nickel-plated steel, electropolished  
316 stainless steel

**CONNECTIONS:** Flange – Flange, 1/2 inch NPT – Flange,  
1/2 inch NPT – 1/2 inch NPT

**ORIFICE SIZE:** 0.187 inch

**STEM PACKING & TYPE:** All 316 stainless steel stems with  
Viton® O-ring and Teflon® back up ring below the threads

All NOSHOK valves are 100% helium leak tested  
to  $1 \times 10^{-4}$  ml/s for guaranteed performance  
and reliability.

All NOSHOK Valve Products  
conform to MSS SP-1999 (R 2005)  
Instrument Valve Standards,  
and valves supplied with packings  
conform to MSS SP-132-2004 Compression  
Packing Systems for Instrument Valves also.



## 3010/3110 SERIES

**NOSHOK DIFFERENTIAL PRESSURE STANDARD MANIFOLDS** are designed for use with differential pressure transmitters incorporating two isolation valves and an equalizing valve in differential pressure measurement. These valves are available in block, single flange or double flange connection for remote or direct installation. The metal-to-metal hard seat valve is pressure rated to 10,000 psi @ 200 °F with a flow coefficient factor of 0.44. The soft seat design features a replaceable Delrin® seat with straight through porting for bi-directional flow and easy roddable cleaning. Maximum pressure rating on the soft seat is 6,000 psi @ 200 °F with a flow coefficient factor of 0.76.

WARRANTY: Three Years†

# 3-VALVE DIFFERENTIAL PRESSURE MANIFOLDS

SOFT SEAT – .375 INCH ORIFICE

## SPECIFICATIONS

**MATERIAL:** Zinc nickel-plated steel, electropolished 316 stainless steel  
**CONNECTIONS:** Flange–Flange, 1/2 inch NPT–Flange, 1/2 inch NPT–1/2 inch NPT  
**ORIFICE SIZE:** 0.375 inch  
**STEM SEAL:** Viton® O-ring and Teflon® back up ring standard,

All NOSHOK valves are 100% helium leak tested to  $1 \times 10^{-4}$  ml/s for guaranteed performance and reliability.

All NOSHOK Valve Products conform to MSS SP-1999 (R 2005) Instrument Valve Standards, and valves supplied with packings conform to MSS SP-132-2004 Compression Packing Systems for Instrument Valves also.

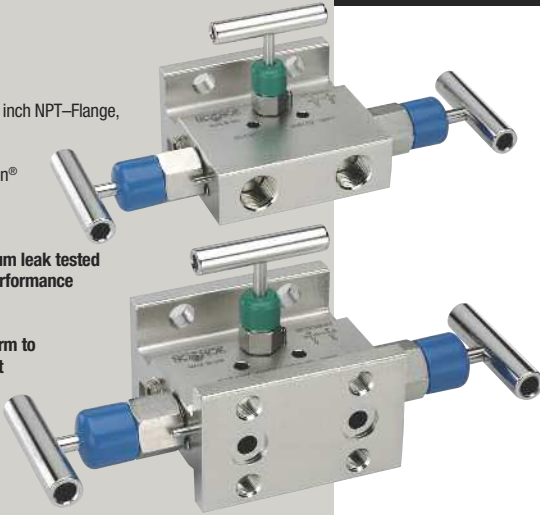

## 3510 SERIES

**NOSHOK DIFFERENTIAL PRESSURE STANDARD MANIFOLDS** are designed for use with differential pressure transmitters incorporating two isolation valves and an equalizing valve in differential pressure measurement. These valves are available in block, single flange or double flange connection for remote or direct installation. The soft seat design features a replaceable Delrin® seat with straight through porting for bi-directional flow and easy roddable cleaning. Maximum pressure rating on the soft seat is 6,000 psi @ 200 °F through a .375 inch bore.

WARRANTY: Three Years†

## SPECIFICATIONS

**MATERIAL:** Zinc nickel-plated steel, electropolished 316 stainless steel  
**CONNECTION:** 1/4 inch NPT  
**ORIFICE SIZE:** 0.141 inch  
**STEM PACKING & TYPE:** Viton® O-ring and Teflon® back up ring standard, Teflon® or Grafol® packing optional

All NOSHOK valves are 100% helium leak tested to  $1 \times 10^{-4}$  ml/s for guaranteed performance and reliability.

All NOSHOK Valve Products conform to MSS SP-1999 (R 2005) Instrument Valve Standards, and valves supplied with packings conform to MSS SP-132-2004 Compression Packing Systems for Instrument Valves also.



HARD SEAT & SOFT TIP

## 3610/3710 SERIES

**NOSHOK DIFFERENTIAL PRESSURE MINI MANIFOLDS** are identical to the 3000/3100 Series Manifold Valves, but in miniature version. They are designed for use with differential pressure transmitters incorporating two isolation valves and an equalizing valve in differential pressure measurement. The metal-to-metal hard seat valve is pressure rated to 10,000 psi @ 200 °F with a flow coefficient factor of 0.44. The patented soft Delrin® tip design is rated to 6,000 psi @ 200 °F.

WARRANTY: Three Years†

# 5-VALVE NATURAL GAS MANIFOLDS

## SPECIFICATIONS

**MATERIAL:** Zinc nickel plated steel, electropolished stainless steel  
**CONNECTIONS:** Flange – Flange, 1/2 inch NPT – Flange, 1/2 inch NPT – 1/2 inch NPT  
**ORIFICE SIZE:** 0.187 inch  
**STEM PACKING & TYPE:** All 316 stainless steel stems with Viton® O-ring and Teflon® back up ring below the threads  
**ADDITIONAL FEATURES:** Two static (test) ports, color coded vinyl bonnet and stem dust cap, patented soft tip stem design on equalizing and vent valves

All NOSHOK valves are 100% helium leak tested to  $1 \times 10^{-4}$  ml/s for guaranteed performance and reliability.

All NOSHOK Valve Products conform to MSS SP-1999 (R 2005) Instrument Valve Standards, and valves supplied with packings conform to MSS SP-132-2004 Compression Packing Systems for Instrument Valves also.



HARD & SOFT SEAT/TIP

## 5030/5130 SERIES

**NOSHOK NATURAL GAS STANDARD MANIFOLDS** are designed for use with differential pressure transmitters incorporating two isolation valves, two equalizing valves and a vent valve in natural gas applications. These valves are available in block, single flange or double flange connection for remote or direct installation. The metal-to-metal hard seat valve is pressure rated to 10,000 psi @ 200 °F with a flow coefficient factor of 0.44. The soft seat design features a replaceable Delrin® seat with straight through porting for bi-directional flow and easy roddable cleaning\*. Maximum pressure rating on the soft seat is 6,000 psi @ 200 °F with a flow coefficient factor of 0.76.

\*Isolation valves only

WARRANTY: Three Years†

SOFT SEAT— .375 INCH ORIFICE

## SPECIFICATIONS

**MATERIAL:** Zinc nickel-plated steel, electropolished stainless steel

**CONNECTIONS:** Flange – Flange, 1/2 inch NPT – Flange, 1/2 inch NPT – 1/2 inch NPT

**ORIFICE SIZE:** 0.375 inch

**STEM SEAL:** All 316 stainless steel stems with Viton® O-ring and Teflon® back up ring below the threads

**ADDITIONAL FEATURES:** Two static (test) ports, color coded vinyl bonnet and stem dust cap, patented soft tip stem design on equalizing and vent valves

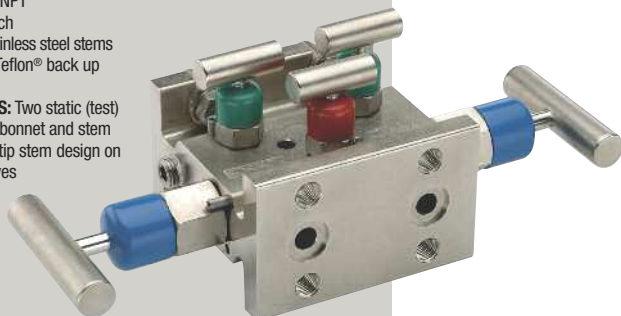

All NOSHOK valves are 100% helium leak tested to  $1 \times 10^{-4}$  ml/s for guaranteed performance and reliability.

All NOSHOK Valve Products conform to MSS SP-1999 (R 2005) Instrument Valve Standards, and valves supplied with packings conform to MSS SP-132-2004 Compression Packing Systems for Instrument Valves also.

## 5530 SERIES

**NOSHOK NATURAL GAS STANDARD MANIFOLDS** are designed for use with differential pressure transmitters incorporating two isolation valves, two equalizing valves and a vent valve in natural gas applications. These valves are available in block, single flange or double flange connection for remote or direct installation. The soft seat design features a replaceable Delrin® seat with straight through porting for bi-directional flow and easy roddable cleaning\*. Maximum pressure rating on the soft seat is 6,000 psi @ 200 °F through a .375 inch bore.

\*Isolation valves only

**WARRANTY:** Three Years†

## VALVE ACCESSORIES

### PRESSURE TO STATIC ADAPTER PLATE

Used in direct mount systems for gas pipelines, the pressure to static adapter plate is used to mount a differential pressure transmitter and a static pressure transmitter to a five valve flange-flange manifold. They are available in electroless nickel plated steel or electropolished stainless steel. An integral mini style bleed valve is incorporated in the plate and a 1/4 inch NPT vent plug is provided. The mini style bleed valve is equipped with a Viton® O-ring and Teflon® back up ring below the stem threads to protect against corrosion and galling. Stem threads are rolled for greater strength and ease of operation and all NOSHOK valves are 100% helium leak tested for guaranteed reliability. Maximum pressure rating of 10,000 psi for steel & stainless steel models.

### DIELECTRIC KIT

The dielectric kit is designed to maintain the integrity and reliability of the pipeline and piping system through safety and corrosion protection. Dielectric kits provide a non-conductive barrier between the process piping and the instrument and isolate components from the effects of electrical current. By eliminating metal-to-metal contact, current is halted to prevent corrosion and aid in the cathodic protection of the system.



### SPECIFICATIONS

**MATERIAL:** Delrin®, PVC

**MAX OPERATING TEMP:** 150° F (66° C)

**DIELECTRIC STRENGTH:** Exceeds 1/32 air arc gap approx 2,500 Vdc

### MANIFOLD MOUNTING KIT

Designed for direct or remote mounting to a two inch pipe stand, can be utilized with any NOSHOK 2, 3 or 5 valve manifold by mounting a steel or stainless steel bracket directly to the manifold body.



### STATIC ADAPTERS

The static adapter is used to join threaded ports to a flange style connection. They are often used on direct mount systems to join the NPT port of a static transmitter with a flange mounted connection on a pressure to static adapter plate. They are available in electroless nickel plated steel and electropolished stainless steel.

### SPECIFICATIONS

**MATERIAL:** Electroless nickel plated 12L14 steel, electropolished stainless steel,

**CONNECTIONS:** 1/2 inch NPT male - Flange

### FUTBOLS

Futbols (flange adapters) bolt to the process side of a flange-flange manifold to allow connection of process flange taps or process root valves. Futbols also allow flanges to be connected to threaded process piping while maintaining the ease of removal or repair of the manifold if maintenance is required. The futbols provide a 1/16 inch offset connection from the bolt holes to give connection centers of 2.0, 2.125, or 2.25 inches



### SPECIFICATIONS

**MATERIAL:** Yellow zinc dichromate plated steel, 316 stainless steel

**CONNECTIONS:** 1/2 inch NPT

**KIT INCLUDES :** (2) Futbols, (4) hex bolts 7/16-20, (2) Teflon® face seals

# NOTES

A page with horizontal lines for writing. The page is overlaid with large, faint, light gray geometric shapes, including a circle and several lines, which are part of the page's design.

TO DOWNLOAD OR ORDER OUR CATALOGS,  
VISIT [WWW.NOSHOK.COM](http://WWW.NOSHOK.COM)

## Quality Policy

NOSHOK is committed to providing a high degree of value and continually improving processes to improve customer satisfaction by focusing on customer requirements for the design, manufacture and distribution of pressure, temperature, and force measurement instruments along with needle and manifold valves.

All from world class technology.

Combined with real-world stamina.

The highest value with the industry's best warranty.

And all from a company with a 40+ year record of customer satisfaction.

All from your Single Source Instrumentation Company.



#### **Corporate Headquarters**

1010 West Bagley Road  
Berea, Ohio 44017  
Ph: 440.243.0888  
Fax: 440.243.3472  
E-mail: [noshok@noshok.com](mailto:noshok@noshok.com)  
Web: [www.noshok.com](http://www.noshok.com)

